

LVCSi FP Flameproof Continuous Level Sensor

The LVCSi FP is an analogue vertical liquid level sensor with an integrated display meter and output driver specifically designed for continuous, in-situ monitoring of your tank while in a potentially explosive atmosphere.



II 1/2G 2D

Ex db IIC T5/T4/T3 Ga/Gb

-40°C ≤ Ta ≤ +85°C

Ex tb IIIC T100°C / T135°C / T200°C Db

-40°C ≤ Ta ≤ +85°C

IP68



II 2GD

Ex db IIC T5/T4/T3 Gb

-40°C ≤ Ta ≤ +85°C

Ex tb IIIC T100°C / T135°C / T200°C Db

-40°C ≤ Ta ≤ +85°C

IP68

Environment and process temperatures

T5 / T100°C for process temperatures ≤ +85°C and ≥ -55°C

T4 / T135°C for process temperatures ≤ +120°C and ≥ -55°C

T3 / T200°C for process temperatures ≤ +180°C and ≥ -55°C

ATEX Certificate: ExVeritas 17ATEX0301X

IECEx Certificate: IECEx EXV17.0030X

Refer to certificate for clarification of directive code and equipment protection level.

The LVCSi-FP features include:

- ATEX and IECEx approved
- Suitable for gas and dust environments
- Stainless steel 316L wetted components
- A display for direct read-out of level and temperature
- Temperature sense range up to +120C
- Two pairs of analogue outputs (4-20mA and 0-10V)
- Two set point digital outputs
- An RS485 communications port
- Reed switch or Hall Effect sensing technology.
- IP Rating of IP68
- Stem Lengths up to 6m
- Custom mounting options available.
- Optional Modbus
- Can be specified for process temperatures down to -55°C
- Optional custom name plate



LVCSi FP Flameproof Continuous Level Sensor

Type	Specification	
Head dimensions	110mm x 100mm x 81mm (Excluding sensor stem and cable glands/port fixings)	
Stem length	Standard sizes are from 250mm to 2000mm in 250mm increments. Custom sizes available on request.	
Level sensing resolution	5mm (reed) or 15mm (Hall-effect)	
Temperature sensing range	-40°C to +120°C	
Temperature sensing resolution	0.1°C	
Max. temperature error	< ±1.0°C over the full sensing range (subject to correct calibration)	
Current-loop output range	4-20mA (with 0mA fault indication)	Note 3
Voltage output ranges	0-10V, 0-5V, 0-2V	
Max. analogue output error	-0.3% to +1.0% full-scale (subject to correct calibration)	
Transistor output	NPN open-collector Maximum pull-up voltage of 36Vdc. Current-limited to 50mA	
Head operating temperature	-40°C to +85°C	
Stem operating temperature		
Reed LVCSi	-20°C to +120°C (standard) -55°C to +180°C (full range)	
Hall-effect LVCSi	-20°C to +80°C	
Power supply	15 – 30Vdc at 100mA	
Fuse	500mA anti-surge Omni-Blok® cartridge	
Mounting Options	½" BSP Custom options available	
Float Diameter: Specific gravity	53mm : 0.65	Other floats available
Operating Pressure	Stem and float 10 Bar standard. Up to 60bar on request	
IP rating with suitable cable gland	IP68	
Sensor tube and wetted materials	Stainless steel 316L	
Connection head material	Stainless steel 316L and glass	
Approximate weight	1.2Kg+process connector + 0.5Kg/Metre	
Maximum liquid temperature	-55°C to +85°C for T5 rated hazardous environment -55°C to +120°C for T4 rated hazardous environment -55°C to +180°C for T3 rated hazardous environment	Note 1
Maximum head temperature	-40 to +80°C	Note 2
Thread connection-Wiring port	Two M20X1.5 ports or Two ½" NPT ports, cable glands not included	

Note 1: LVCSi FP for liquids with maximum temperature above 120°C or minimum temperatures below -20°C are available – please call the sales office for assistance.

Note 2: When this equipment is intended to be used in a liquid with a process temperature above +85°C or below -40°C it is an essential requirement that the sensor head temperature is measured to determine if the ambient air temperature is sufficient to keep the head temperature between -40°C and +80°C. See installation manual for detail.

Note 3: Maximum load resistance is determined by the formula:

$$R_{load(max)} = (\text{supply Voltage} - 2V) / 20mA.$$

At maximum specified voltage and temperature, the minimum load resistance increases to approximately 500Ω

An approximate formula is:

$$R_{load(min)} = (\text{Supply voltage}) / 20mA - (150C - (\text{Ambient temperature})) / 0.04C/\Omega$$

LVCSi FP Flameproof Continuous Level Sensor

The LVCS FP and LVCSi FP range of analogue level sensors feature a magnetic float moving along a stem to provide a continuous analogue output that indicates liquid level. Sensors in the stem detects small step-changes in level and the output gives a continuous analogue signal.

The following range of user-selectable analogue outputs are supplied as standard: 0-2V, 0-5V, 0-10V and the industrial standard 4-20mA current loop. Level outputs can be inverted, ideal for level sensors mounted from the bottom of a tank.

The standard LVCSi FP is designed to fit a 21mm hole in the top of a tank, secured by its stainless steel head, and has a ½ inch NPT thread. Sensing resolution is 5mm with measuring lengths of 250mm, 500mm, 750mm and 1000mm or 15mm resolution with 1250mm, 1500mm, 1750mm and 2000mm Hall-effect sensing technology. It is housed in a robust stainless steel instrument enclosure that screws to the top of a sensor stem and has a tempered glass viewing window.

All fittings to the stem are made from 316L stainless steel and are welded to make a tough and durable sensor. The LVCSi FP is therefore ideally suited for use in food and petrochemical applications, and for use in harsh environments. It also has an IP rating of IP68.

The optional Modbus protocols allow for full remote monitoring and setup. The LVCSi FP conforms to the Modbus RTU and Modbus ASCII command and response framing standards as a slave device – please see the manual for details.

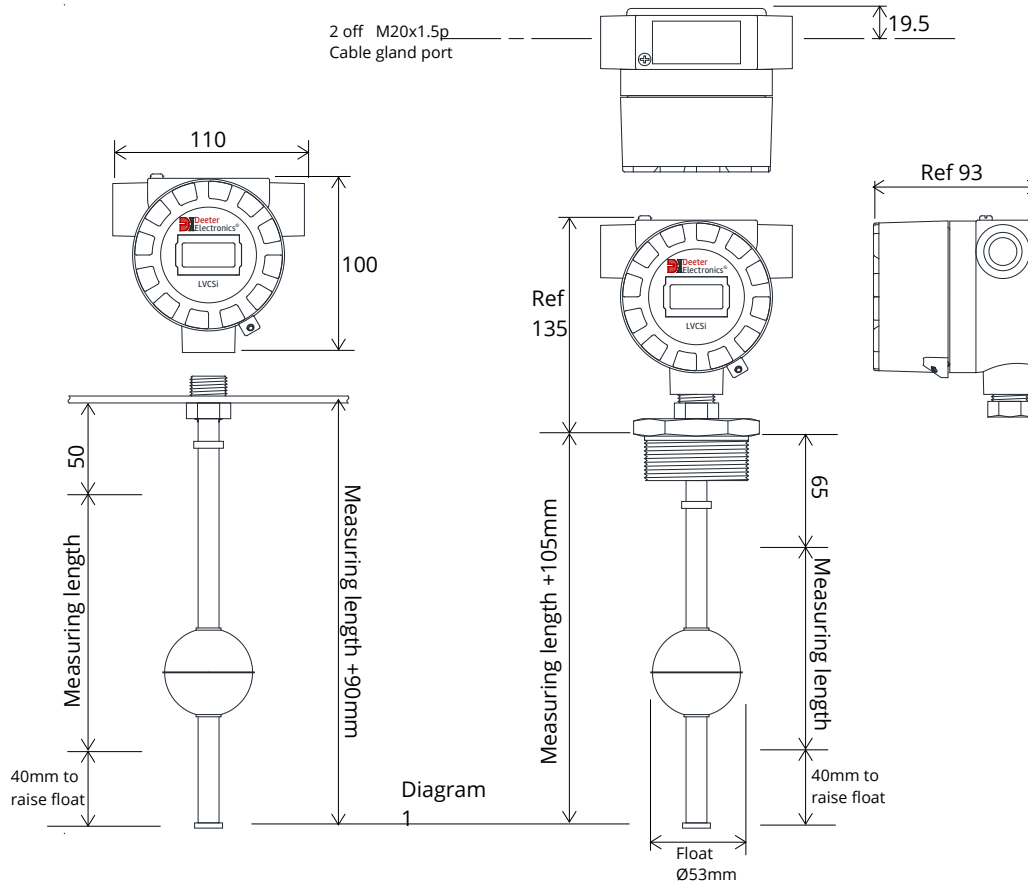

LVCSi FP Flameproof Continuous Level Sensor

Ordering information

Due to the various options available please call our sales office to discuss your requirements or order from the standard part No options below.

Options include: Probe length, Threaded mounting/seal options, Reed/Hall Effect technology, ATEX 'T' rating, non-standard float size, Output voltage, No temperature sensing, Mod bus, Custom name plate / Logo.

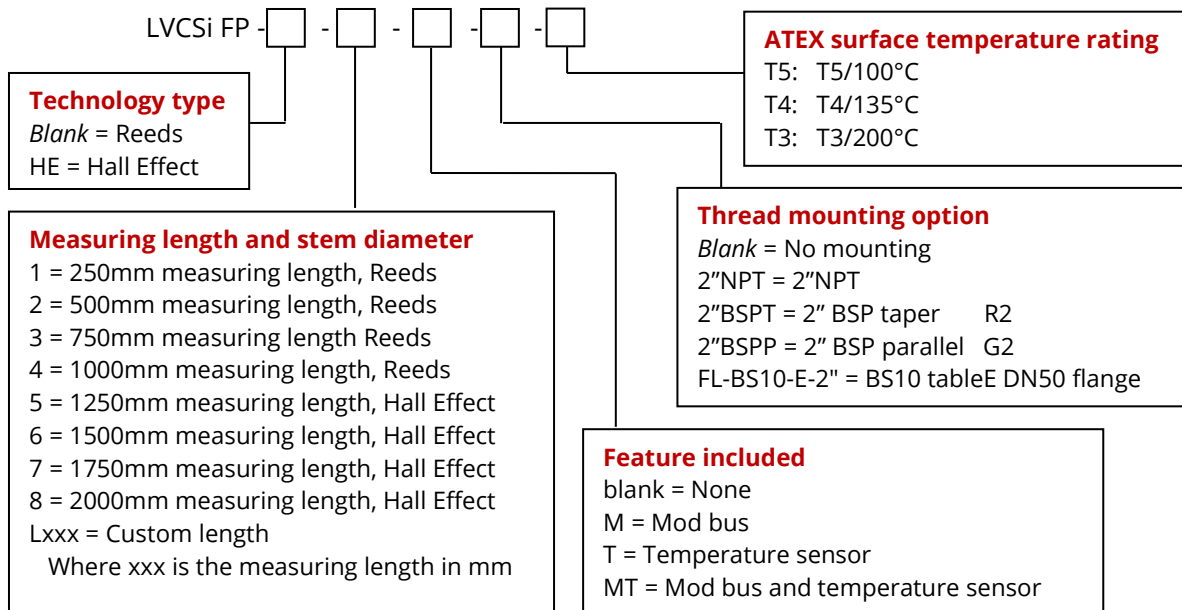

Upon receipt of the above information a drawing and Deeter part No. will be issued to identify the options selected. This part No. will be required when making your order.

Don't forget: Tank depth must be at least 90mm longer than the measuring length.

Example: LVCSi FP HE-L1635-T-2"BSPT-T5 is a Flame proof liquid level sensor using Hall Effect technology. Measuring length =1635mm, Overall sensor length =1740mm, Temperature sensor included, 2"BSP taper pipe fitting welded to the top of the stem for mounting the sensor into a tank of liquid, T5 temperature rating for liquid process temperatures between -55°C and +85°C

All electrical equipment should be installed by a qualified/certified electrician.

Deeter Electronics follows a policy of continual development of its products and reserves the right to change specifications and/or features without notice.

LVCSi FP Flameproof Continuous Level Sensor

Identification

The LVCSi FP sensors covered by this document can be identified by the label attached to the sensor head. Both the head label and the sensor tube end stop are marked with their date of manufacture in the form of 2 letters. The S/N:xxxxxx is a unique serial No. given to each piece of equipment. The LVCSi FP:xxxxxx is a 6 digit model code. The model code is also the Deeter reference number of a drawing which identifies the dimensions and features included. A copy of this drawing should be attached to this manual. The temperature class shown here as a * will be either T5/T100 °C, T4/T135°C or T3/T200°C

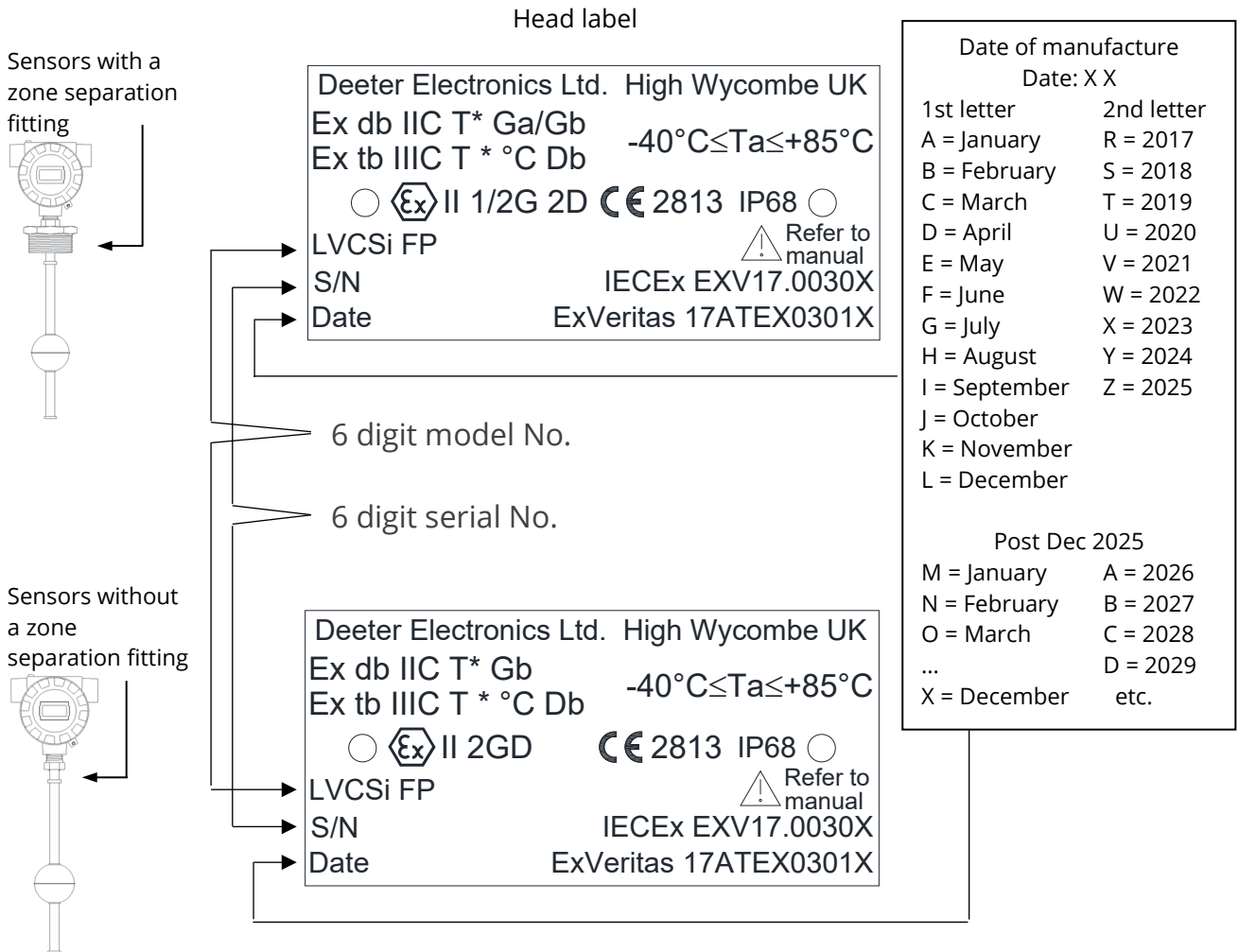

Diagram 2

LVCSi FP Flameproof Continuous Level Sensor

Instruction for mounting and wiring a LVCSi FP

1) This document details the installation of all versions of standard Deeter LVCSi FP and their optional mounting / zone seal. Separate documents are available for LVCS, LVCS FP and LVCSi



2) Do not open the lid or disconnect any part of the sensor when an explosive atmosphere may be present.

This device must be installed in accordance with IEC/EN60079-14

3) LVCSi FP without a custom mounting option can be installed by suspending the sensor over the liquid as shown in diagram 3 and 4.

Only LVCSi FP with a custom mounting, as shown in diagram 5, can be installed across a Zone 0 and Zone 1 boundary. It is essential that equipment mounted across a Zone 0 and Zone 1 boundary are installed with a sufficiently tight join in accordance with clause 4.6 of EN60079-26 to provide an IP67 seal between zones.

4) All versions of LVCSi FP must be mounted vertically $\pm 5^\circ$ with the head positioned so it will not become immersed in liquid during normal operation. A LVCSi FP with a liquid tight seal can be mounted from the bottom of a tank with the stem above the head if required.

The magnetic float and sensor stem must be installed away from any magnetic field or ferrous materials which could influence its operation.

Mounting and wiring must only be carried out in a safe environment.

5) All versions of LVCSi FP must be mounted where the ambient temperature will allow the sensor head to cool to below $+80^\circ\text{C}$ or remain above -40°C . This is especially significant where the process temperature is above $+85^\circ\text{C}$ or below -40°C .

6) The standard LVCSi FP sensor is supplied ready to mount through a 22.5mm hole in the top of a tank or onto a mounting bracket as shown in diagram 3. When the thickness of the tank or bracket exceeds 4mm thick ensure the head can be screwed onto the stem with a minimum of 5 revolutions and be wrench tight without gripping or being restricted by the bracket. Bracket thickness can never exceed 10mm.

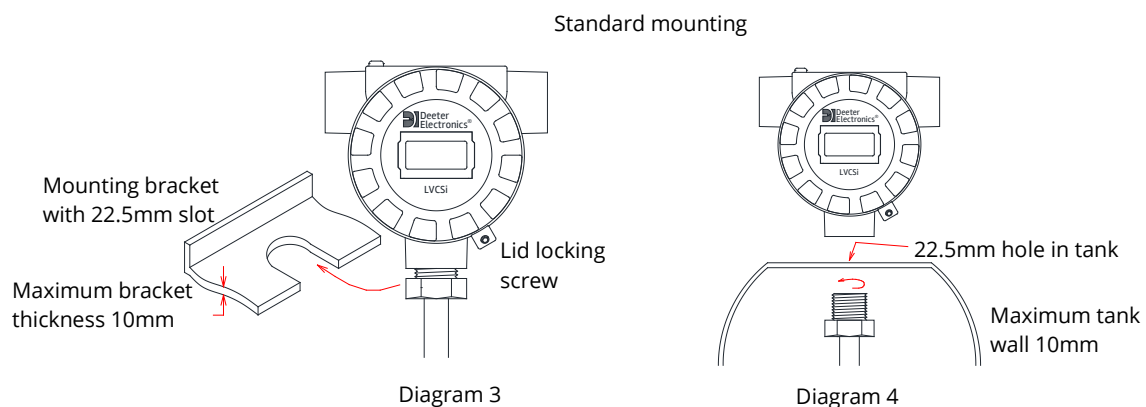

LVCSi FP Flameproof Continuous Level Sensor

7) Loosen the lid locking screw and unscrew the front of the head. Detach the wires going into the sensor stem by pulling the connector off the circuit board.

Unscrew the stem from the head.

The use of a soft metal tommy bar screwed into the cable gland entry to facilitate additional leverage if required. Care must be taken to not damage the cable entry thread by using excessive force, striking the tommy bar or using a non-threaded bar.

A 150mm long brass tommy bar is available from Deeter Electronics if required.

Remove old PTFE tape and apply several layers of new PTFE tape to the male thread. As an alternative, a non setting grease according to EN 60079-1 clause 5.1 may be used to replace the PTFE tape. Failure to apply PTFE tape or grease may lead to thread galling and irreparable damage to this thread.

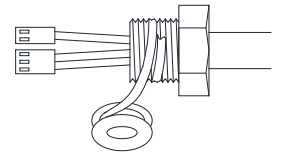
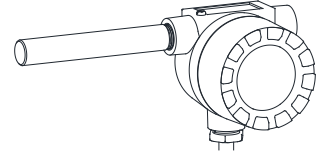

8) Mount the stem in the tank and screw the head back on top.

Clamp the head and use a 24mm spanner on the stem hexagon to tighten the joint. Do not use grips on the tube or end stop.

The head / stem joint must be tightened with a minimum of 5 revolutions of thread engagement.

Ensure the stem is tight into the head and it has not gripped the mounting bracket or tank wall.

9) LVCSi FP with a custom mounting do not require the separation of the head and stem, but during installation the head/stem joint should be checked that it is secure as described above.

10) All LVCSi FP with custom mounting options are supplied with a drawing to identify the supplied fitting. The supplied mounting will enable the installer to screw or clamp the sensor into place. It is not possible to install a sensor by welding as the welding process will damage the sensors internal electronics. When tightening a threaded pipe fittings as shown in diagram 5, do not use the grips on the stem or use the head as a lever, always use a spanner on the pipe fitting.

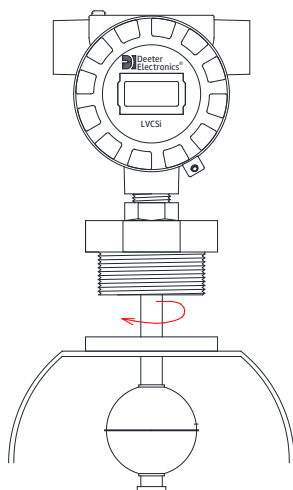
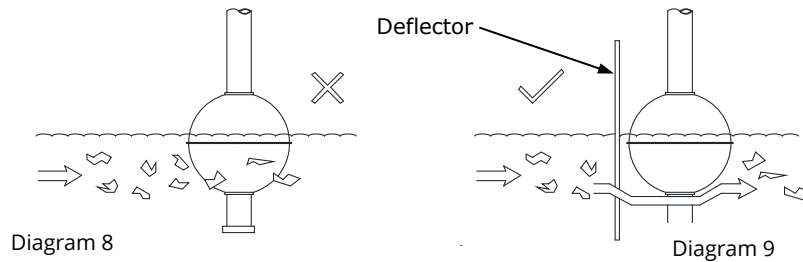

Diagram 7

LVCSi FP Flameproof Continuous Level Sensor



11) When a sensor is installed in a position where it may be exposed to excessive vibration, stress or impact from liquid bound particles. Then the sensor must be protected by additional support or deflectors as shown in diagram 7.



12a) When this equipment is intended to be used in a liquid with a process temperature above +85°C it is an essential requirement that the sensor head temperature is measured to determine if the ambient air cooling is sufficient to keep the head below +80°C. With the sensor stem immersed to its maximum level in the process liquid at maximum temperature, a measurement of the temperature at the base of the head must be taken. Consideration of the ambient temperature during the measurement should be made and an evaluation of the maximum temperature the sensor head may reach should be recorded. Where the head temperature is expected to rise above 80°C then additional air cooling is required to keep the head below +80°C. When the sensor is intended for use in a dust environment the above test should be carried out with a layer of dust covering the sensor head.



12b) When this equipment is intended to be used in a liquid with a process temperature below -40°C it is an essential requirement that the sensor head temperature is measured to determine if the ambient air temperature is sufficient to keep the head above -40°C. With the sensor stem immersed to its maximum level in the process liquid at minimum temperature, a measurement of the temperature at the base of the head must be taken. Consideration of the ambient temperature during the measurement should be made and an evaluation of the minimum temperature the sensor head may reach should be recorded. Where the head temperature is expected to drop below -40°C then additional air heating is required to keep the head above -40°C. When the sensor is intended for use in a dust environment the above test should be carried out with a layer of dust covering the sensor head.

LVCSi FP Flameproof Continuous Level Sensor



13) With the LVCSi FP mounted in the tank the cables can be connected.
The sensor head is not normally supplied with a cable gland so the installer is free to select a suitable explosion proof gland or conduit to mate with the M20X1.5pitch port in the stainless steel head.
When selecting components to attach to the LVCSi FP the following conditions should be considered.



Cable glands must be EXd flameproof cable gland for enclosures with internal volume ≥ 0.5 litres and suitable for gas, zone, temperature and cable type being used.
IP6x glands must be used in dust environments



If ambient temperature around the sensor head is greater than $+65^{\circ}\text{C}$ the connecting cable and its gland or stopping box must be able to withstand the increased temperature range. These components must have a minimum temperature specification of 5°C above the maximum possible ambient temperature and have a minimum ingress protection rating of IP68.
When using conduit a stopping box must be fitted no more than 50mm from the sensor head. The stopping box and conduit must be installed in accordance with clause 13.2.2 IEC/EN60079-1.

LVCSi FP Flameproof Continuous Level Sensor

14) To open the terminal enclosure first loosen the lid locking grub screw. Unscrew the window lid and lift away the display mask surrounding the LCD display.

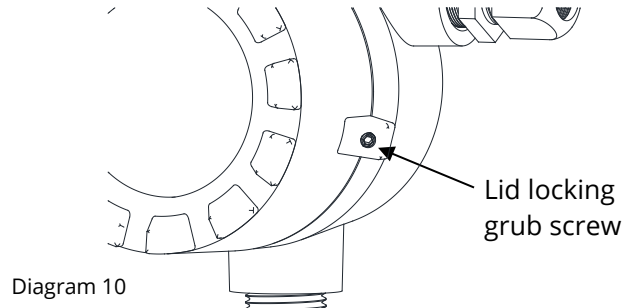

Remove the two M3 screws holding the display circuit to the enclosure. Lift the circuit board module off the two mounting posts. The circuit board module consists of two circular PCBs and a display PCB. Do not attempt to separate the individual circuit boards from each other. Disconnect the internal wires if required by pulling off the connector from the back of the circuit board module. Take care not to pull on the wires attached to the sensor stem.

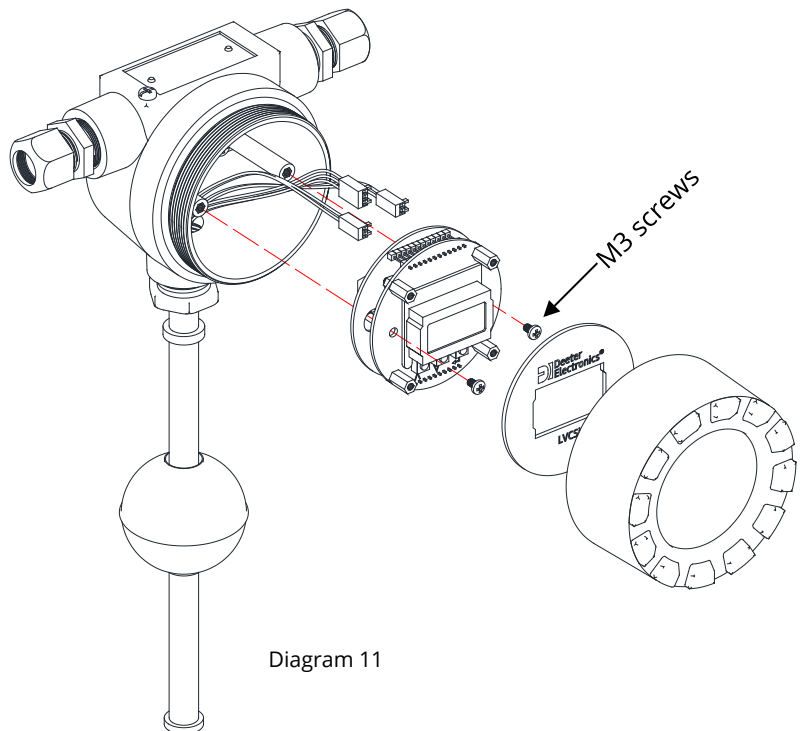

Cable restraint.

15) Thread the cable through the LVCSi FP enclosure and through the plastic washer. Tightly fix the cable tie around the cable 150mm from the end. When the wiring below is complete the cable can be pulled back through the enclosure until the plastic washer and tie wrap prevent the cable being withdrawn any further.

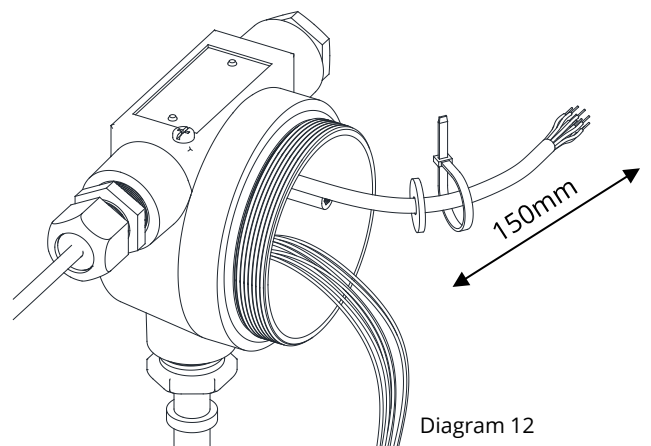

LVCSi FP Flameproof Continuous Level Sensor

Wiring.

16) All external connections go to the two rows of screw terminals on the underside of the bottom PCB. The connecting wires must be between 16 to 22AWG (Metric capacity 1.5mm²) and with 6mm stripped ends. For heavy industrial environments where strong radiated electromagnetic fields can be expected, it is recommended that screened cables should be used for the serial communications and analogue voltage outputs. The screen can be terminated at the screw stud inside the enclosure.

Not all screw terminals need to be connected. The connections made will depend if the temperature option was included and which outputs are required to be permanent wired e.g. RS485, digital outputs and whether current loop and voltage analogue output are required simultaneously. It should be noted there is insufficient space through the cable entry and behind the terminal board for all the terminals to be connected using the larger wire sizes.

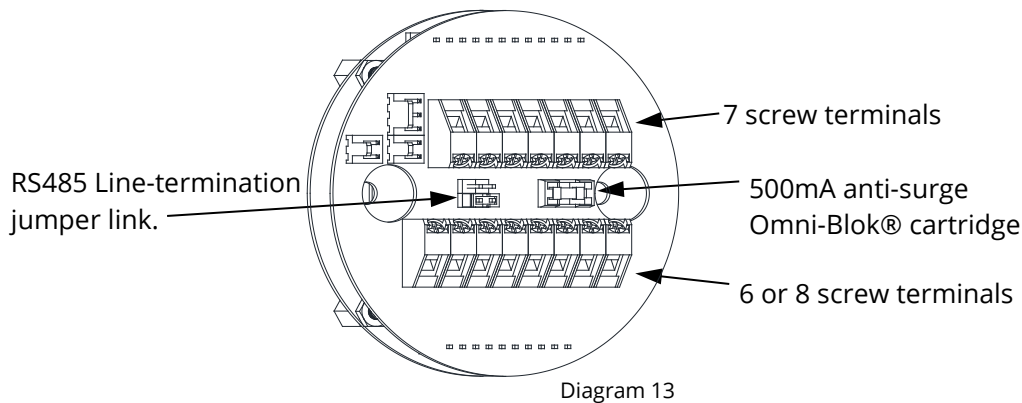

Earth

The earth wire must be connected.

Attach the earth wire to either the internal or external protective earth point on the head using the crimp terminal provided. The M4 earth screws are coloured green and the location is marked with the earth symbol.

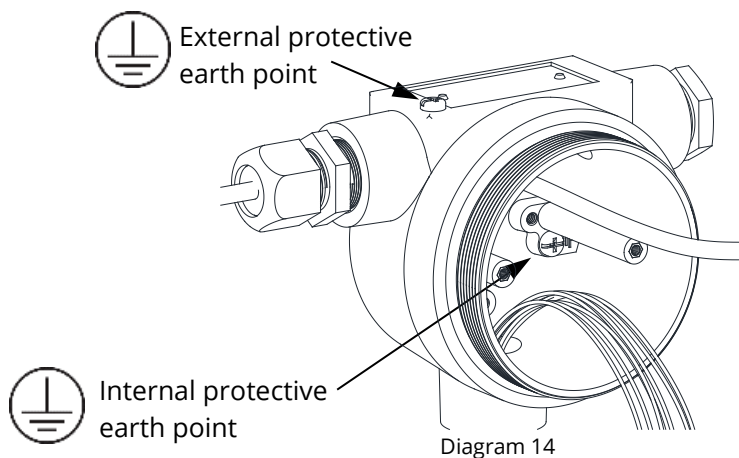

LVCSi FP Flameproof Continuous Level Sensor

Power Supply

Power requirements are 15Vdc to 30Vdc at 100mA.

Connect the positive wire to the 'POWER Vin' terminal and the negative wire to 'POWER 0V'.

Analogue Outputs

There are two independently driven analogue outputs, each having terminals for voltage and current, making four analogue outputs in total. These are arranged as a single block of 8 screw terminals on the underside of the bottom PCB. (If a temperature sensor is not fitted, this is a 6-way connector with no provision for the Analogue Output 2 current-loop).

Analogue Output 1 is always assigned to level. Output 2 can be assigned to level or temperature.

Connections can be made to both sets of terminals from a single analogue output and the voltages and currents will correlate. However, if 5V or 2V output ranges are selected the current will be limited to ranges of 4-12mA or 4-7.2mA. Also, the calibration adjustments used for a channel are based on the choice of current or voltage output (see section 4.7), so the other output will be slightly out of adjustment.

Digital Outputs

Terminals DO1 and DO2 are open-collect transistor outputs and an external pull-up is required in the off state.

Space limitations mean that separate 0V or power supply terminals are not available for the full range of equipment that could be connected to the digital outputs. Depending on the nature of the equipment, wires may share with the POWER 0V or Vin terminals as shown in the examples of the diagram below.

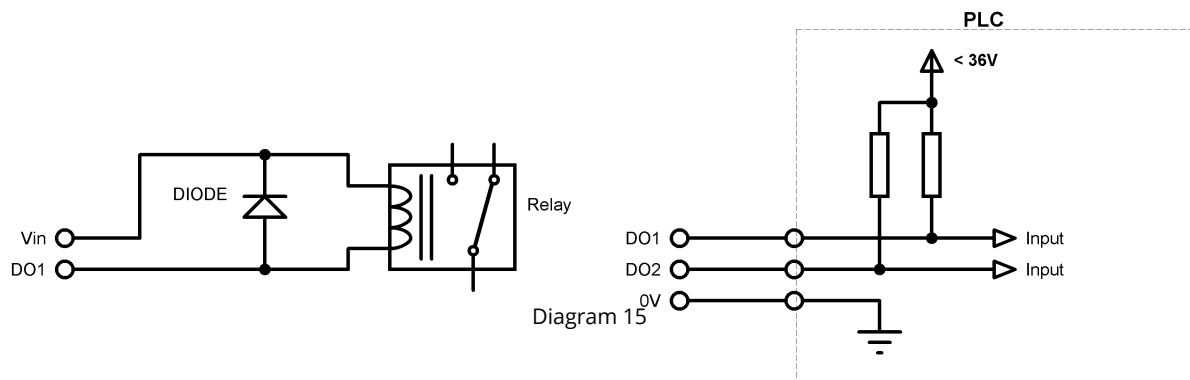

The transistors outputs are protected from transient voltages, but for inductive loads, further suppression is recommended close to the source. In the case of a relay, a diode (e.g. 1N4001) will provide protection as show above.

LVCSi FP Flameproof Continuous Level Sensor

RS485 Communications

The RS485 serial communications port is half-duplex, using the balanced-pair lines D+ and D-. Connections to the bus master are:

LVCSi	MASTER
D+	D+ or A
D-	D- or B
0V	0V or SC or G

A line-termination resistor can be enabled by moving LK1 to the TERM position. For a multi-drop configuration only the end device should have this link in the TERM position. See Diagram 13

Inverting the LVCSi

The LVCSi can be mounted to the top or bottom of a tank. Default settings are for top-mounting, with low analogue and display levels associated with the float at the end of the stem away from the head.

If mounting the LVCSi the other way up (e.g. below a tank):

- Mount the display the other way up inside its housing
- Reverse display settings by making the 'LOW' level greater than the 'HIGH' level (see section 4.2)
- Select 'INVERT' for analogue outputs (see section 4.5)
- Convert digital output threshold percentages by subtracting from 100%

Note that the standard position of the temperature sensor and the standard stem mounting fixtures may not be suitable for an inverted LVCSi. Alternatives are available on request.

17) After connecting the earth, supply and output wires screw the lid down hand-tight, keep applying torque by hand until the lid cannot be turned any further. Tighten the lid-locking screw so the lid cannot be accidentally removed.

The electrical connections to a safe power supply and monitoring device depends on the output type of your LVCS FP sensor.

LVCSi FP Flameproof Continuous Level Sensor

Configuration Setup

Three push buttons are used to navigate the configuration menus. These buttons are located below the display and are only accessible with the housing cover unscrewed, so configuration setup needs to be performed during installation. If Modbus communications options are used, most setup parameters (excluding communications settings) can be changed remotely at any time.

Below each button is a symbol to indicate its function:

SYMBOL	FUNCTION
^	UP
v	DOWN
↵	ENTER

In the following sections the buttons are referred to as UP, DOWN and ENTER.

Option menus are organised into levels, with all top-level menus indicated by the enter symbol ↵ in the bottom right corner or the display.

The symbols ^ and v to the right of the display indicate that holding UP or DOWN buttons will rapidly increment or decrement the parameter on the screen.

Option Menus

Option menus are accessed from normal operation (or fault states) by pressing and holding the ENTER button for 3 seconds.

Pressing UP or DOWN will cycle through the top-level menus and ENTER will select a sub-menu. ENTER pressed from the EXIT menu will return to normal operation.

Temperature Display and Temperature Calibration menus are not shown if a temperature sensor is not fitted.

L	E	V	E	L					
D	I	S	P	L	A	Y	↵		

T	E	M	P						
D	I	S	P	L	A	Y	↵		

D	I	S	P	L	A	Y			
B	R	I	G	H	T		↵		

LVCSi FP Flameproof Continuous Level Sensor

A	N	A	L	O	G	U	E
O	U	T		1			↩

A	N	A	L	O	G	U	E
O	U	T		2			↩

A	N		O	U	T		
C	A	L	I	B			↩

T	E	M	P				
C	A	L	I	B			↩

D	I	G	I	T	A	L	
S	E	T	U	P			↩

D	I	G	I	T	A	L	
O	P		T	E	S	T	↩

C	O	M	M	S			
S	E	T	U	P			↩

	E	X	I	T			
							↩

4.1 Level Display

During normal operation the top line of the display is reserved for level information. The first sub-menu selects the location of the decimal place. The five options are:

3		P	L	A	C	E	S
1	.	0	0	0			

2		P	L	A	C	E	S
1	0	.	0	0			

LVCSi FP Flameproof Continuous Level Sensor

1		P	L	A	C	E
1	0	0	.	0		

0		P	L	A	C	E	S
1	0	0	0	.			

x	1	0				
1	0	0	0	0	.	

The 'x10' option multiplies all numbers by ten without increasing resolution, so the last digit is shown as zero.

The second sub-menu selects the display range, starting with the lower end associated with the float at the bottom of the stem:

	L	O	W			^
-	1	0	.	0	0	v

The third sub-menu selects the top end of the display range, associated with the float at the top of the stem:

	H	I	G	H		^
	1	0	.	0	0	v

The fourth and final sub-menu selects display units:

U	N	I	T	S	
<	n	o	n	e	>

Unit options are listed in Table 1.

4.2 Temperature Display

Temperature can be displayed in degrees Celsius, degrees Fahrenheit or in Kelvin

C	E	L	S	I	U	S
	2	0	.	4	°	C

F	A	H	'	H	E	I	T
	6	8	.	7	°	F	

LVCSi FP Flameproof Continuous Level Sensor

K	E	L	V	I	N
2	9	3	.	6	K

If Fahrenheit is selected, other menus will show temperatures in Fahrenheit. These include the Temperature Calibration menu, Analogue Output 2 ranges and associated zero offset menus (if Analogue Output 2 is assigned to temperature), and Digital Output thresholds (if assigned to temperature).

If Fahrenheit is selected, the Deeter ASCII communications protocol will also report in Fahrenheit. However, all Modbus commands and responses are in degrees Celsius.

If Kelvin is selected, the display and Deeter ASCII temperature command (T) are in Kelvin. Other display menus and communications responses are in degrees Celsius.

4.3 Display Brightness

This sub-menu selects the quiescent LCD backlight level. Settings are in the range 0% to 80%.

B	R	I	G	H	T	^
5	0	%				v

LVCSi FP Flameproof Continuous Level Sensor

4.4 Analogue Output 1

Analogue Output 1 is always associated with the level input. The first sub-menu is used to select output range.

A	N	O	U	T	1
4	-	2	0	m	A

A	N	O	U	T	1
0	-	1	0	V	

A	N	O	U	T	1
0	-	5	V		

A	N	O	U	T	1
0	-	2	V		

UP and DOWN cycle through the 4 options.

The 4-20mA and 0-10V options produce the same outputs. They differ in that the 4-20mA option will raise an alarm if the current loop is broken, or if the loop resistance is too great or supply voltage is too low for the driver IC to achieve the correct output current.

Output calibration adjustments are based on the choice between current and voltage. If a voltage output is chosen, the voltage output will be correctly adjusted but the current output may be slightly out. Similarly, if the current output is selected, corrections will be based on a different set of calibration settings and the voltage output may be out.

ENTER advances to an option to invert the output:

I	N	V	E	R	T	Y
A	N	1				N

UP and DOWN toggle between Y (yes) and N (no), indicated by an underscore cursor. ENTER saves the selected option and exits back to the top level menu.

LVCSi FP Flameproof Continuous Level Sensor

4.5 Analogue Output 2

For an LVCS stem with a temperature sensor, Analogue Output 2 can be assigned to level or temperature and the first sub-menu is used to make that selection:

A	N	O	U	T	2
L	E	V	E	L	

A	N	O	U	T	2
T	E	M	P		

Whichever input is chosen, the second sub-menu selects output range:

A	N	O	U	T	2
4	-	2	0	m	A

A	N	O	U	T	2
0	-	1	0	V	

A	N	O	U	T	2
0	-	5	V		

A	N	O	U	T	2
0	-	2	V		

With a temperature sensor fitted the four options are: 4-20mA, 0-10V, 0-5V and 0-2V. With no temperature sensor there are three options: 0-10V, 0-5V and 0-2V.

If LEVEL was chosen, ENTER advances to a third sub-menu to invert the output:

I	N	V	E	R	T	Y
A	N	2				N

UP and DOWN toggle between Y and N, indicated by an underscore cursor. ENTER saves and exits back to the top level menu

LVCSi FP Flameproof Continuous Level Sensor

If TEMP was chosen, ENTER advances to a third sub-menu to select the temperature range:

R	A	N	G	E
1	6	0	°	C

R	A	N	G	E
1	0	0	°	C

R	A	N	G	E
	8	0	°	C

R	A	N	G	E
	5	0	°	C

The four range options are: 160°C, 100°C, 80°C and 50°C. Output resolutions for combinations of input and output ranges are shown in Table 2.

If the full 160°C range was chosen ENTER returns to the top level menu, otherwise it advances to a fourth sub-menu to select the starting temperature for the output range, i.e. the temperature to be associated with zero output (4mA for current loop):

A	N	2	Z	E	R	O
		0	°	C		

For the 100°C range the zero can be between -40°C and +20°C
 For the 80°C range the zero can be between -40°C and +40°C
 For the 50°C range the zero can be between -40°C and +70°C

4.6 Analogue Output Calibration

The LVCSi is calibrated during manufacture and under normal circumstances further adjustments should not be necessary.

In order to perform calibration adjustments effectively, set Analogue Output 2 to LEVEL and both output channels to a full range, either 4-20mA or 0-10V (see section 4.6).

Each calibration setting consists of a 'Zero' and 'Span'. The Zero is a constant offset applied across the range, presented as a percentage of full scale. A +1.0% Zero adjustment will add 0.16mA to the current output at 4mA and at 20mA.

The Span adjustment stretches or shrinks the output proportionately across the range. A +1.0% Span will add 0mA at the 4mA end and 0.16mA at the 20mA end of the current output range.

LVCSi FP Flameproof Continuous Level Sensor

C	1	Z	0	.	2	%
		1	.	9	%	

C	1	S	0	.	1	%
	9	8	.	0	%	

V	2	Z	-	0	.	5	%
		2	.	0	%		

V	2	S	1	.	0	%
	9	7	.	5	%	

The three top left characters indicate current (C) or voltage (V), channel number (1 or 2) and Zero (Z) or Span (S).

There are separate calibration settings for the current-loop and voltage outputs for each output channel, making four sets of calibration settings in total. However, if 4-20mA was selected for an output channel only the calibration menus for current are presented, and if a voltage output was selected only calibration menus for voltage are presented.

The top right of the display shows the calibration parameter as a percentage between -1.0% and +1.0% (the plus symbol not displayed).

The bottom line indicates the present input level shown in the range and units selected in the Level Display menus. The default level display is in percentages to one decimal place.

To perform calibration, connect suitable measuring instruments to the analogue outputs and follow these steps:

- In the Zero menu set the level to around 2% of full-scale
- Use UP and DOWN buttons to adjust the output to match the display level
- Adjust the level slightly to observe how closely display and output match
- Press ENTER to save calibration setting and advance to the Span menu
- Set the level to around 98% full scale
- Use UP and DOWN buttons to adjust the output to match the display level
- Adjust the level slightly to observe how closely display and output match
- Repeat for Analogue Output 2

LVCSi FP Flameproof Continuous Level Sensor

4.7 Temperature Sensor Calibration

This menu is only seen if a temperature sensor is fitted.

Calibration is performed during manufacture at an indoor ambient temperature and further adjustments should not be necessary. The adjustment is a fixed offset applied across the full temperature range and accuracy will be greatest close to the temperature at which calibration is performed.

+	0	.	3	°	C
2	1	.	1	°	C

Use UP and DOWN buttons to adjust the displayed temperature to match a reference source. Note that the LVCS stem may have a slower thermal response than the reference, so calibration should only be performed when temperatures are steady.

4.8 Digital Output Setup

For an LVCS stem with a temperature sensor, Digital Outputs can be assigned to level or temperature and the first sub-menu is used to make that selection:

T	R	A	N	S	1
L	E	V	E	L	

T	R	A	N	S	1
T	E	M	P		

If LEVEL is chosen, thresholds are shown as percentages starting with the ON threshold and followed by the OFF threshold:

T	1	O	N	^
	9	0	%	v

T	1	O	F	F	^
	8	0	%		v

LVCSi FP Flameproof Continuous Level Sensor

If TEMP is chosen, thresholds are shown as a temperature in degrees Celsius (integers only)

T	1	O	N	^
-	1	0	°	C

T	1	O	F	F	^
	3	0	°	C	v

ENTER advances to Transistor 2 settings. Options for Transistor 2 are equivalent to those shown above for Transistor 1.

4.9 Digital Output Test

In this menu the transistor outputs can be exercised without the need to manipulate sensor inputs. This is useful for checking wiring and output operation during installation.

T	1			T	2
O	F	F		O	N

UP and DOWN buttons toggle the output indicated by the blinking cursor. ENTER cycles through T1, T2 and the top level menu.

4.10 Communications Setup

The first sub-menu selects baud rate:

	B	A	U	D
1	9	2	0	0

Options are: 2400, 9600, 19200 and 38400

If Modbus options are not available ENTER returns to the top level menu, otherwise the second sub-menu allows the communications protocol to be selected:

D	E	E	T	E	R
P	R	O	T	O	C

M	O	D	B	U	S
A	S	C	I	I	

M	O	D	B	U	S
R	T	U			

LVCSi FP Flameproof Continuous Level Sensor

If either Modbus option is selected ENTER advances to the Modbus address menu, otherwise it exits to the top level menu.

A	D	D	R	E	S	S	^
0	0	1					v

UP and DOWN buttons are used to select an address within the decimal range 001 to 247. Press ENTER to return to the top level menu.

1. Operating States

Those display states not associated with setup are referred to as 'operating states'. These include a Start-up state, Normal Operation and several fault states. Fault states will automatically revert to normal operation once the fault is cleared.

The LCD backlight will be at full brightness for 20 seconds after power-up, 20 seconds after any button press, or continuously during any fault condition. In the normal state the backlight will dim to the level selected in setup.

5.1 Start-up

The display shows the firmware version for 5 seconds when the LVCSi is switched on, then advances to normal operation or fault states.

L	V	C	S	i
V	1	.	0	1

5.2 Normal Operation

During normal operation the top line of the display will show level information and the bottom line will show the temperature.

	2	.	4	5	L
2	0	.	7	°	C

If a temperature sensor is not used, the bottom line will be blank.

5.3 Missing Level Sensor

If the level sensor is disconnected, the display shows 'NO INPUT' on the top line.

N	O	I	N	P	U	T
2	0	.	7	°	C	

Outputs associated with the level input will go to 0mA and 0V.

LVCSi FP Flameproof Continuous Level Sensor

If a gap is detected in the level sensor at power-up, this message will be seen. It will clear as soon as a valid input is detected. This may indicate a fault in the stem, but is normal for some types of LVCS.

5.4 Missing Temperature Sensor

If the LVCSi is configured for a temperature sensor and this is disconnected, the bottom line will show 'NO INPUT'.

		2	.	4	5	L
N	O		I	N	P	U T

Outputs associated with temperature will go to 0mA and 0V.

5.5 Current-Loop Fault

If a current loop output has been assigned and there is an open circuit, or the driver IC cannot generate an output voltage high enough to reach the target current, the word 'OPEN' will appear on the display. The number will show which of the two analogue outputs is faulty.

O	P	E	N	1
2	0	.	7	° C

5.6 Supply Voltage

If the supply voltage goes below 13V or exceeds 31V, the display will show a warning.

S	U	P	P	L	Y
1	2	.	9	V	

S	U	P	P	L	Y
>	3	1	.	0	V

5.7 RS485 Serial Communications

The LVCSi is a slave device responding to commands initiated by an RS485 bus master. The data format is fixed as:

8 data bits, no parity, 1 stop bit.

There are four user-selectable baud rates:

2400, 9600, 19200, 38400.

Three communication protocols are supported:

- Deeter ASCII
- Modbus RTU
- Modbus ASCII

LVCSi FP Flameproof Continuous Level Sensor

6.1 Deeter ASCII Protocol

The Deeter ASCII protocol uses commands and responses with displayable ASCII characters. This makes commands easy to generate and responses easy to view and interpret on a PC with terminal-emulation software.

There are ten commands that request reports on sensor activity, setup and status, but do not allow changes to be made to setup parameters. Commands are all single, upper-case characters in the range A to Z. Other characters in the range A to Z will be ignored and characters outside this range will elicit the response, B<CR>, where <CR> represents the carriage-return character (0Dh).

Table 3 lists the commands and example responses. All responses start with the command character and are terminated with the carriage-return character (not shown).

Table 3

Command Character	Command Function	Example Response
A	Analogue Output Settings	A 01,+0.2,+0.0, -0.1,+0.1, 51, -0.1,+0.1,+0.0, -0.3, -40
C	Temperature Sensor Calibration Offset	C -0.1
D	Display Settings	D +0000,+1000,11,00,25
E	Transistor Settings	E 010,020,090,080
L	Level	L 0684
N	Firmware Version	N LVCSi V1.01,2,T,M
S	Status	S 01
T	Temperature	T +24.1
V	Supply Voltage	V 23.3
Z	Level Zero Calibration	Z 2158

A Analogue Output Settings contains 11 comma-separated numbers:
 An1 settings
 An1 current zero, An1 current span, An1 voltage zero, An1 voltage span
 An2 settings
 An2 current zero, An2 current span, An2 voltage zero, An2 voltage span
 Temperature Zero

An1 and An2 settings are hexadecimal numbers with bits defined as follows:

LVCSi FP Flameproof Continuous Level Sensor

Table 4

Bit	Bit Clear (0)	Bit Set (1)	Comment
7			Not used, always 0
6	Output assigned to level	Output assigned to temperature	An2 only
5,4	11 = 50°C output range 10 = 80°C 01 = 100°C 00 = 160°C		Temperature assignment only
3			Not used, always 0
2	Normal output 11 = 0-2V 10 = 0-5V	Inverted output	Level assignment only
1,0	01 = 0-10V 00 = 4-20mA		

Zero and span are calibration settings for the analogue outputs, both numbers in the range -1.0 to +1.0

Temperature Zero is the temperature that corresponds to the lowest analogue output – see section 4.6. Valid range is -40 to +70 (sign plus two digits) in degrees Celsius or -040.0 to +158.0 (sign, decimal place and four digits) in Fahrenheit. This number is omitted from the response if there is no temperature sensor.

C Temperature Sensor Calibration Offset is a calibration setting for the sensor between -10.0°C (-18.0°F) and +10.0 (+18.0°F). If there is no sensor the response is C<CR>.

D The Display Settings report has five comma-separated numbers:
 LOW
 HIGH
 Level decimal places & units
 Temperature units
 Backlight brightness

LOW and HIGH (see section 4.2) are in the range -1000 to +1000

LVCSi FP Flameproof Continuous Level Sensor

The level-decimal-places-and-units number is hexadecimal with the following bit assignments:

Table 5

Bits	Function	Bit Settings
7	Not used, always 00	
6,5,4	Number of decimal places	100 = x10 011 = 3 010 = 2 001 = 1 000 = 0 1111 = Gal 1110 = pt 1101 = ml 1100 = cl 1011 = L 1010 = L 1001 = ' 1000 = ft 0111 = ' 0110 = in 0101 = mm 0100 = cm 0011 = m 0010 = m 0001 = % 0000 = no units
3,2,1,0	Units	

Temperature units are:

00	=	°C
01	=	°F
10	=	K

Backlight brightness is a decimal number between 00 and 80 (see section 4.4)

- E** Transistor Settings contains the four transistor threshold numbers in the order: Tr1 ON
- Tr1 OFF
 - Tr2 ON
 - Tr2 OFF

Level thresholds are in the decimal range 000 to 100.

Temperature thresholds are preceded by a sign and are in the range -40 to +120 (sign plus three digits) in degrees Celsius, or -40.0 to +248.0 (sign, decimal place and four digits) in degrees Fahrenheit.

LVCSi FP Flameproof Continuous Level Sensor

- L** Level reports show the current float level in decimal between 0000 and 1000
- N** The firmware version is the same as that displayed on power-up.
Up to three comma-separated characters follow the version number:
 '2', '3' or 'H' identifies the stem type (2-wire reed, 3-wire reed or Hall-effect).
 'T' indicates that the temperature sensor is enabled
 'M' indicates that Modbus options are available
- S** The status report has a single number with two digits. The first digit has the following meaning:
 0 = system okay
 1 = setup menus open
 2 = fault detected
Interpretation of the second digit depends on the first digit. When status is 'okay' or a setup menu is open, the second digit indicates the present state of the digital outputs:
 0 = digital outputs off
 1 = output 1 on
 2 = output 2 on
 3 = outputs 1 and 2 on
If a fault has been detected, the second digit identifies the fault:
 1 = LVCS stem missing
 2 = Temperature sensor missing (if enabled)
 3 = Power supply under voltage
 4 = Power supply over voltage
 5 = Current loop 1 open/high resistance (if An1 set to 4-20mA)
 6 = Current loop 2 open/high resistance (if An2 set to 4-20mA)
 7 = Both current loop circuits are open or high resistance
- T** Temperature reports are to one decimal place in °C, °F or K
- V** Supply voltage reports are to one decimal place in volts. The report will typically be 0.7V lower than the supply at the input connector.
- Z** Level Zero Calibration is a factory setting. If not calibrated, Hall-effect and 3-wire reed LVCS responses are Z<CR>.

LVCSi FP Flameproof Continuous Level Sensor

6.2 Modbus RTU

Modbus RTU is a de facto standard, having achieved wide acceptance for connecting industrial devices without rigid standardisation or formal acceptance by standards authorities.

The LVCSi conforms to the Modbus RTU command and response framing standard as a slave device. Detailed descriptions of this standard are readily available on the world-wide web.

6.2.1 Supported Function Codes

The supported functions will allow the monitoring of level and temperature sensors, device status and setup, and will also allow remote changes to setup parameters.

Table 6 lists the function codes supported.

Table 6

Function Code	Function Name	Description
3	Read Holding Registers	Reads a set of 16-bit read/write registers
4	Read Input Registers	Reads a set of 16-bit read-only registers
6	Write Single Holding Register	Writes to a single 16-bit read/write register
16	Write Multiple Holding Registers	Writes to a set of 16-bit read/write registers

Commands containing other Modbus function codes will elicit an exception code response.

6.2.2 Register Assignments

There are ten read/write registers, accessed by function codes 3, 6 and 16, as defined in Table 7. Attempts to write values outside permitted ranges will elicit an exception code response.

Table 7

Register	Address	Description	Comments
40001	0000	Analogue Output 1 settings	See bit assignment details below
40002	0001	Analogue Output 2 settings	
40003	0002	Transistor 1 ON threshold	Details below
40004	0003	Transistor 1 OFF threshold	
40005	0004	Transistor 2 On threshold	
40006	0005	Transistor 2 OFF threshold	Details below
40007	0006	Display settings	
40008	0007	Display level LOW	
40009	0008	Display level HIGH	
40010	0009	Display brightness setting	0-80

LVCSi FP Flameproof Continuous Level Sensor

There are eleven read-only registers, accessed by function code 4, defined as follows:

Table 8

Register	Address	Description	Comments
30001	0000	Firmware version	e.g. V1.02 will be sent as 0102
30002	0001	Status code	See details below
30003	0002	Level report	0000 to 1000
30004	0003	Temperature report	0000 to 1600 in 0.1°C units, origin at -40.0°C
30005	0004	Supply voltage	Units of 0.1V
30006	0005	Analogue current output 1 calibration	
30007	0006	Analogue voltage output 1 calibration	Zero (high byte) and Span (low byte) as separate 8-bit
30008	0007	Analogue current output 2 calibration	2's complement numbers. Units of 0.1% of full span
30009	0008	Analogue voltage output 2 calibration	
30010	0009	Temperature calibration offset	8-bit 2's complement. Units of 0.1°C
30011	000A	Level zero calibration	0000 = uncalibrated

6.2.3 Bit Assignments

The Analogue Output settings in registers 40001 and 40002 have the following bit-assignments:

Table 9

Bit	Description	Comments
15-8	Temperature output zero	Range of 0-110 with 0 = -40°C
7	(not used)	Writes to here must be 0. Read as 0
6	Level/Temperature assignment	0=level, 1=temperature (An2 only)
		11 = 50°C
		10 = 80°C
5,4	Temperature output range	01 = 100°C
		00 = 160°C
3	(not used)	Writes to here must be 0. Read as 0
2	Level normal/invert	0=normal, 1=invert
		11 = 0-2V
		10 = 0-5V
1,0	Output range	01 = 0-10V
		00 = 4-20mA

LVCSi FP Flameproof Continuous Level Sensor

Registers 40003 to 40006 contain the transistor ON and OFF thresholds. Level thresholds are between 0 and 100 percent; temperature thresholds are in degrees Celsius from -40°C to +120°C represented as numbers from 0 to 160.

Register 40007 contains the display settings shown in Table 10

Table 10

Bits	Function	Bit Settings	Comments
15-11	(not used)		Writes must be 0. Read as 0
10,9,8	Level number of decimal places	100 = x10	
		011 = 3	
		010 = 2	
		001 = 1	
		000 = 0	
7,6	(not used)		Writes must be 0. Read as 0
5,4	Temperature Units	10 = K	
		01 = °F	
		00 = °C	
		1111 = Gal	
		1110 = pt	
		1101 = ml	
		1100 = cl	
		1011 = L	
		1010 = L	
		1001 = '	
		1000 = ft	
		0111 = '	
		0110 = in	
3,2,1,0	Level Units	0101 = mm	
		0100 = cm	
		0011 = m	
		0010 = m	
		0001 = %	
		0000 = no units	

LVCSi FP Flameproof Continuous Level Sensor

The status code in register 30002 is defined in Table 11

Table 11

Bit	Bit-Set Description	Comments
15	Normal Operation State active	If clear and bits 14-8 are also clear, menus are active and settings may be changing
14	Start-up State	Other status bits may not be settled and could soon change
13	Disconnected level sensor	
12	Disconnected temperature sensor	
11	Supply voltage too high	>31V
10	Supply voltage too low	<13V
9	Analogue Output 2 alarm	4-20mA setting only. Current loop open or high
8	Analogue Output 1 alarm	resistance
7	(not used)	Read as 0
6	Hall-effect LVCS	
5	2-wire reed LVCS	Bits 6 and 5 both clear = 3-wire reed LVCS
4	Temperature sensor enabled	
3,2	(not used)	Read as 00
1	Transistor 2 active	
0	Transistor 1 active	

6.2.4 Broadcast and Exception Responses

If the Modbus broadcast address is received (address zero), the LVCSi will act on the command without sending a response. This address is only meaningful for the write function codes 6 and 16.

If the LVCSi detects another slave's address it will ignore the command and not respond. If the received command is corrupted and a redundancy check error is detected, the LVCSi will also ignore this command and not respond.

If the slave address is correct and there are no errors in the transmission, but the LVCSi cannot action the command for another reason, it will reply with an exception response.

LVCSi FP Flameproof Continuous Level Sensor

Maintenance/Repair

The electrical supply to the sensor is connected through a fuse to limit excess current should a fault occur. See diagram 13 for location of the 2.69X2.69X6.1mm 500mA anti-surge Omni-Blok® cartridge fuse.

Any repairs or replacements parts (excluding fuse replacement) must be carried out by the manufacturers or their appointed repair agent.

Sensors with a long unsupported stem or in contact with fast moving liquids should include a maintenance plan to inspect the welded joints for fracture and fatigue.

A sensor stem immersed in hot or aggressive chemicals should be checked for corrosion on a regular basis with special attention to the stem end stop weld.

Where additional air cooling or heating was required in the installation process, the effectiveness of this should be checked as described in section 12.

The three flameproof threads as show in diagram 17, and there interconnecting parts must be clean and free from dust or debris before assembly.

Damage to flameproof threads must not be Repaired - contact Deeter Electronics for replacements.

The Oring under the head cover should be inspected for damage.

Remove dust from devices with large mounting flange or plug.

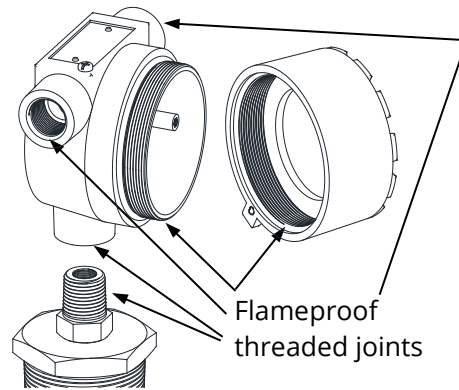

Diagram 17

Storage

Store in dry conditions without strong magnetic influence. Protect the float from impact.

Transport

Transport in rigid container with sensor head supported. Support sensor stem evenly and limit the float from moving along the stem. Protect float sides from impact by supporting sensor stem in the middle of the packing. Remove packing material from around the float to avoid secondary impact to the float. The float must not be used to support the stem.

1 EU - Type Examination Certificate

2 Equipment intended for use in Potentially Explosive Atmospheres Directive 2014/34/EU

3 Certificate Number: ExVeritas 17ATEX0301X Issue: 2

4 Equipment: Liquid Vertical Continuous Sensor, Flameproof (LVCS FP) Float Switch,
Flameproof (F/S FP) Liquid Vertical Continuous Sensor with integrated
display, Flameproof (LVCSi FP)

5 Manufacturer: Deeter Electronics Ltd

6 Address: Deeter House, Valley Road, Hughenden Valley, High Wycombe, Bucks,
HP14 4LW, UK

7 This equipment and any acceptable variation thereto are specified in the schedule to this certificate and the documents therein referred to.

8 ExVeritas, Notified Body number 2804 in accordance with Article 17 of the Council Directive 2014/34/EU of 26 February 2014, certifies that this equipment or protective system has been found to comply with the Essential Health and Safety Requirements relating to design and construction of equipment and protective systems for use in potentially explosive atmospheres given in Annex II to the Directive

9 Compliance with the applicable Essential Health and Safety Requirements has been assured by compliance with the following Standards and section 16 of this certificate:

BS EN IEC 60079-0: 2018 BS EN 60079-1:2014 BS EN 60079-26:2015
BS EN 60079-31:2014

10 If the sign "X" is placed after the certificate number, it indicates that the equipment is subject to special conditions for safe use specified in the schedule to this certificate.

11 This EU-Type Examination Certificate relates only to the design, construction, examination and tests of the specified equipment or protective system in accordance to the Directive 2014/34/EU. Further requirements of the Directive apply to the manufacturing process and supply of this equipment or protective system. These are not covered by this certificate.

12 The marking of the equipment shall include the following:

 II 1/2G (or 2G) Ex db IIC T* Ga/Gb (or Gb) -55°C ≤ T_{amb} ≤ +85°C

 II 2 D Ex tb IIIC T* Db -40°C ≤ T_{amb} ≤ +85°C

On behalf of ExVeritas



Peter Lauritzen
Managing Director

Schedule

13 Description of Equipment or Protective System

The LVCS FP (Liquid Vertical Continuous Sensor) and F/S FP (Float Switch) are liquid level sensors with either a continuous analogue or switching output. The equipment comprises of a flameproof, component certified instrument housing with stainless steel level guide which is threaded into the housing. The level guide consists of either an 8mm or 12mm stainless steel tube which contains the sensing electronics. The instrument housing is used for termination and mounting of optional PCB's, depending on the communication and I/O's required. The level guides can be various lengths and are mounted with up to seven stainless steel floats, each containing a magnetic ring. The equipment can be supplied with an optional threaded adaptor or equivalent gas tight seal for mounting across a boundary of two hazardous area zones.

When connected to process temperatures above 85°C, the instrument housing must be sufficiently cooled to keep it below 80°C, as detailed in the manufacturer's instructions.

The following temperature classes are applicable based on the process temperature which the equipment is connected to:

Model	Level guide length (mm)	Sensing device	Input/Output Options	Process Temperature and associated temperature class	Cable Entry sizes
LVCS	100 to 6000	Reed switch or Hall effect	Optional PCB's for various input/outputs	≤85°C (T5) (T100°C) ≤125°C (T4) (T135°C) ≤180°C (T3) (T200°C)	M20 x 1.5 or ½" NPT
F/S	60 to 6000	Reed switch	Between 1 to 7 I/O float switches, direct output	≤85°C (T5) (T100°C) ≤125°C (T4) (T135°C) ≤190°C (T3) (T200°C)	M20 x 1.5 or ½" NPT

The following ratings are applicable:

- 0 to 2v output. 5 to 25vdc input @ 25mA
- 0 to 4 v output. 7 to 25Vdc input @ 25mA
- 0 to 10v output. 14 to 28vdc input @ 35mA
- 8 to 28vdc input @30mA Multi interface 4-20mA, voltage output
- 0-50VDC 0-240V AC 1Amp (F/S FP reed switch only)

13.1 Details of changes

The following changes are incorporated in Issue 1 of the certificate:

- Update to the latest edition of EN 60079-0 as detailed on page 1 of the certificate.
- Inclusion of the LVCSi range of vertical liquid level sensors with integrated display and optional temperature sensor.

Model	Level guide length (mm)	Sensing device	Input/Output Options	Process Temperature and associated temperature class	Cable Entry sizes
LVCSi	100 to 6000	Reed switch or Hall effect. Optional temperature sensor	Optional PCB's for various input/outputs	≤85°C (T5) (T100°C) ≤125°C (T4) (T135°C) ≤180°C (T3) (T200°C)	2 off M20 x 1.5 or 2 off ½" NPT

10-30Vdc @ 100mA

The marking of the LVCSi range shall include the following:

 II 1/2G (or 2G) Ex db IIC T* Ga/Gb (or Gb) -40°C ≤ T_{amb} ≤+85°C

Certificate: ExVeritas 17ATEX0301X

Issue 2

This certificate may only be reproduced in its entirety and without any change, schedule included.

For help or assistance relating to this certificate, contact info@exveritas.com.

ExVeritas ApS, Severinsmindevej 6, 4420 Regstrup, Denmark.

ExVeritas® is a registered trademark, unauthorised use will lead to prosecution.

Schedule

 II 2 D Ex tb IIIC T* Db $-40^{\circ}\text{C} \leq T_{\text{amb}} \leq +85^{\circ}\text{C}$

13.2 Details of changes

- Transfer of the certificate from ExVeritas UK, Notified Body number 2585 to ExVeritas Denmark, Notified Body number 2804. Certificate number remains unchanged.

14 Descriptive Documents

14.1 Associated Report and Certificate History:

Report Number	Cert Issue Date	Issue	Comment
R1288/A/1	14/12/2017	0	Initial issue of the Prime Certificate
R2757/A/1	24/09/2020	1	Issue of the first variation.
EXV4121A	15/09/2022	2	Issue of the second variation.

14.2 Compliance Drawings:

Number	Date	Issue	Description
D 600779	29/11/2017	2	LVCS FP all versions Sheet 1 of 2
D 600779_2	29/11/2017	3	LVCS FP all versions Sheet 2 of 2
D 600781	29/11/2017	2	F/S FP all versions Sheet 1 of 2
D 600781_2	29/11/2017	3	F/S FP all versions Sheet 2 of 2
Dwg 950553	11/8/2017	2	Adaptor 1/2" NPT Long thread to 12mm Sheet 1 of 2
Dwg 950568	11/8/2017	2	Adaptor 1/2" NPT long thread to 8mm Sheet 1 of 2
D600850	11 th March 2020	Rev 1	LVCSi FP all versions (Sheets 1 to 2)
-	17/09/2020	-	LVCSi FP manual

15 Conditions of Certification

15.1 Special Conditions for Safe Use

- When intended to be operating with process temperatures above 85°C, the sensor head shall be sufficiently cooled to keep it below 80°C. See installation manual for details.
- The LVCSi may be operated with process temperatures down to -55°C, when used at temperatures below -40°C, the sensor head shall be kept at a temperature of at least -40°C. See installation manual for details.
- Refer to manual for cable entry thread size and type.

15.2 Conditions for Use

- The LVCS FP and F/S FP range of sensors are subject to a routine tests on production in accordance with clause 16 of EN/IEC 60079-1 to a pressure of at least 57.2 Bar.
- The level guide assembly of the LVCSi FP shall be subject to a routine over pressure test in accordance with clause 16 of EN/IEC 60079-1 to a pressure of at least 17.2 Bar.
- The equipment covered under this certificate incorporates previously certified components, it is therefore the responsibility of the manufacturer to monitor the status of the certification of these components and inform ExVeritas of any changes that may affect the explosion safety design of their products.

Certificate: ExVeritas 17ATEX0301X

Issue 2

This certificate may only be reproduced in its entirety and without any change, schedule included.

For help or assistance relating to this certificate, contact info@exveritas.com.

ExVeritas ApS, Severinsmindevej 6, 4420 Regstrup, Denmark.

ExVeritas® is a registered trademark, unauthorised use will lead to prosecution.



Schedule

16 Essential Health and Safety Requirements

Essential Health and Safety Requirements are addressed by the standards listed in section 9 and where required the report listed in section 14.1

The manufacturer shall inform the Notified Body of any modifications to the design of the product described by this schedule.

Certificate: ExVeritas 17ATEX0301X

Issue 2

This certificate may only be reproduced in its entirety and without any change, schedule included.

For help or assistance relating to this certificate, contact info@exveritas.com.

ExVeritas ApS, Severinsmindevej 6, 4420 Regstrup, Denmark.

ExVeritas® is a registered trademark, unauthorised use will lead to prosecution.



IECEX Certificate of Conformity

INTERNATIONAL ELECTROTECHNICAL COMMISSION IEC Certification System for Explosive Atmospheres

for rules and details of the IECEx Scheme visit www.iecex.com

Certificate No.: **IECEX EXV 17.0030X** Page 1 of 6 [Certificate history:](#)
Issue 0 (2017-12-19)

Status: **Current** Issue No: 1

Date of Issue: 2020-09-25

Applicant: **Deeter Electronics Limited**
Deeter House, Valley Road
Hughenden Valley
High Wycombe
Bucks
HP14 4LW
United Kingdom

Equipment: **Liquid Vertical Continuous Sensor, Flameproof (LVCS FP) and Float Switch, Flameproof (F/S FP)**

Optional accessory:

Type of Protection: **Equipment protection by flameproof enclosure "d", Equipment with EPL Ga and Equipment dust ignition protection by enclosure "t"**

Marking: Ex db IIC T* Ga/Gb or Ex db IIC T* Gb $-50^{\circ}\text{C} \leq \text{Tamb} \leq +85^{\circ}\text{C}$
Ex tb IIIC *°C Db $-40^{\circ}\text{C} \leq \text{Tamb} \leq +85^{\circ}\text{C}$

Approved for issue on behalf of the IECEx
Certification Body:

S Clarke CEng MSc MIET

Position:

Certification Manager

Signature:
(for printed version)

Date:

1. This certificate and schedule may only be reproduced in full.
2. This certificate is not transferable and remains the property of the issuing body.
3. The Status and authenticity of this certificate may be verified by visiting www.iecex.com or use of this QR Code.



Certificate issued by:

ExVeritas Limited
Units 16-18 Abenbury Way
Wrexham Ind. Est.
Wrexham LL 139UZ
United Kingdom





IECEX Certificate of Conformity

Certificate No.: **IECEX EXV 17.0030X**

Page 2 of 6

Date of issue: 2020-09-25

Issue No: 1

Manufacturer: **Deeter Electronics Limited**
Deeter House, Valley Road
Hughenden Valley
High Wycombe, Bucks, HP14 4LW
United Kingdom

Additional
manufacturing
locations:

This certificate is issued as verification that a sample(s), representative of production, was assessed and tested and found to comply with the IEC Standard list below and that the manufacturer's quality system, relating to the Ex products covered by this certificate, was assessed and found to comply with the IECEx Quality system requirements. This certificate is granted subject to the conditions as set out in IECEx Scheme Rules, IECEx 02 and Operational Documents as amended

STANDARDS :

The equipment and any acceptable variations to it specified in the schedule of this certificate and the identified documents, was found to comply with the following standards

IEC 60079-0:2017 Explosive atmospheres - Part 0: Equipment - General requirements
Edition:7.0

IEC 60079-1:2014-06 Explosive atmospheres - Part 1: Equipment protection by flameproof enclosures "d"
Edition:7.0

IEC 60079-26:2014-10 Explosive atmospheres – Part 26: Equipment with Equipment Protection Level (EPL) Ga
Edition:3.0

IEC 60079-31:2013 Explosive atmospheres - Part 31: Equipment dust ignition protection by enclosure "t"
Edition:2

This Certificate **does not** indicate compliance with safety and performance requirements other than those expressly included in the Standards listed above.

TEST & ASSESSMENT REPORTS:

A sample(s) of the equipment listed has successfully met the examination and test requirements as recorded in:

Test Reports:

[GB/EXV/ExTR17.0029/00](#)

[GB/EXV/ExTR20.0072/00](#)

Quality Assessment Report:

[GB/SIR/QAR12.0004/07](#)



IECEx Certificate of Conformity

Certificate No.: **IECEx EXV 17.0030X**

Page 3 of 6

Date of issue: 2020-09-25

Issue No: 1

EQUIPMENT:

Equipment and systems covered by this Certificate are as follows:

The LVCS FP (Liquid Vertical Continuous Sensor) and F/S FP (Float Switch) are liquid level sensors with either a continuous analogue or switching output. The equipment comprises of a flameproof, component certified instrument housing with stainless steel level guide which is threaded into the housing. The level guide consists of either an 8mm or 12mm stainless steel tube which contains the sensing electronics. The instrument housing is used for termination and mounting of optional PCB's, depending on the communication and I/O's required. The level guides can be various lengths and are mounted with up to seven stainless steel floats, each containing a magnetic ring. The equipment can be supplied with an optional threaded adaptor or equivalent gas tight seal for mounting across a boundary of two hazardous area zones.

When connected to process temperatures above 85°C, the instrument housing must be sufficiently cooled to keep it below 80°C, as detailed in the manufacturer's instructions.

The following temperature classes are applicable based on the process temperature which the equipment is connected to:

Model	Level guide length (mm)	Sensing device	Input/Output Options	Process Temperature and associated temperature class	Cable Entry sizes
LVCS	100 to 6000	Reed switch or Hall effect	Optional PCB's for various input/outputs	≤85°C (T5) (T100°C) ≤125°C (T4) (T135°C) ≤180°C (T3) (T200°C)	M20 x 1.5 or ½" NPT
F/S	60 to 6000	Reed switch or Hall effect	Between 1 to 7 I/O float switches, direct output	≤85°C (T5) (T100°C) ≤125°C (T4) (T135°C) ≤190°C (T3) (T200°C)	M20 x 1.5 or ½" NPT

SPECIFIC CONDITIONS OF USE: YES as shown below:

- When intended to be operating with process temperatures above 85°C, the sensor head shall be sufficiently cooled to keep it below 80°C. See installation manual for details.
- The LVCSi may be operated with process temperatures down to -55°C, when used at temperatures below -40°C, the sensor head shall be kept at a temperature of at least -40°C. See installation manual for details.
- Refer to manual for cable entry thread size and type.



IECEx Certificate of Conformity

Certificate No.: **IECEx EXV 17.0030X**

Page 4 of 6

Date of issue: 2020-09-25

Issue No: 1

Equipment (continued):

The following ratings are applicable:

- 0 to 2v output. 5 to 25vdc input @ 25mA
- 0 to 4 v output. 7 to 25Vdc input @ 25mA
- 0 to 10v output. 14 to 28vdc input @ 35mA
- 8 to 28vdc input @30mA Multi interface 4-20mA, voltage output
- 0-50VDC 0-240V AC 1Amp (F/S FP reed switch only)

Routine Tests:

- The LVCS FP and F/S FP range of sensors are subject to a routine tests on production in accordance with clause 16 of EN/IEC 60079-1 to a pressure of at least 57.2 Bar.
- The equipment covered under this certificate incorporates previously certified components, it is therefore the responsibility of the manufacturer to monitor the status of the certification of these components and inform ExVeritas of any changes that may affect the explosion safety design of their products.
- The level guide assembly of the LVCSi shall be subject to a routine over pressure test in accordance with clause 16 of EN/IEC 60079-1 to a pressure of at least 16.3 Bar.



IECEX Certificate of Conformity

Certificate No.: **IECEX EXV 17.0030X**

Page 5 of 6

Date of issue: 2020-09-25

Issue No: 1

DETAILS OF CERTIFICATE CHANGES (for issues 1 and above)

The following changes are introduced:

- Update to IEC 60079-0 Edition 7.0
- Inclusion of the LVCSi range Vertical Liquid Level Sensor with integrated display and optional temperature sensor.

Model	Level guide length (mm)	Sensing device	Input/Output Options	Process Temperature and associated temperature class	Cable Entry sizes
LVCSi	100 to 6000	Reed switch or Hall effect, Optional temperature sensor	Optional PCB's for various input/outputs	≤85°C (T5) (T100°C) ≤125°C (T4) (T135°C) ≤180°C (T3) (T200°C)	2 off M20 x 1.5 or 2 off 1/2" NPT

Rating - 10-30Vdc @ 100mA

The marking of the LVCSi range shall include the following:

Ex db IIC T* Ga/Gb (or Gb) -40°C ≤ Tamb ≤ +85°C

Ex tb IIIC T* Db -40°C ≤ Tamb ≤ +85°C



IECEx Certificate of Conformity

Certificate No.: **IECEx EXV 17.0030X**

Page 6 of 6

Date of issue: 2020-09-25

Issue No: 1

**Additional information:
Technical Documents:**

Title:	Drawing No.:	Rev. Level:	Date:
LVCSi FP all versions Sheets 1 to 2)	D600850	Rev 1	11 th March 2020
LVCSi FP manual	-	-	17/09/2020