



Flameproof LVCS FP Continuous Level Sensor

The Deeter LVCS FP is a magnetic float on a reed switch or Hall Effect sensor stem for control and indication of a liquid level while in a potentially explosive atmosphere.

 II 1/2G 2D
Ex db IIC (*) Ga/Gb $-55^{\circ}\text{C} \leq \text{Ta} \leq +85^{\circ}\text{C}$
Ex tb IIIC (*) Db $-40^{\circ}\text{C} \leq \text{Ta} \leq +85^{\circ}\text{C}$
IP68

 II 2GD
Ex db IIC (*) Gb $-55^{\circ}\text{C} \leq \text{Ta} \leq +85^{\circ}\text{C}$
Ex tb IIIC (*) Db $-40^{\circ}\text{C} \leq \text{Ta} \leq +85^{\circ}\text{C}$
IP68

* Temperature class options to suit environment and process temperatures
T5 / T100°C for process temperatures $\leq 85^{\circ}\text{C}$
T4 / T135°C for process temperatures $\leq 125^{\circ}\text{C}$
T3 / T200°C for process temperatures $\leq 180^{\circ}\text{C}$

ATEX Certificate: ExVeritas 17ATEX0301X
IECEX Certificate: IECEX EXV 17.0030X
Refer to certificate for clarification of directive code and equipment protection level.



Features include:

- ATEX and IECEX approved.
- Standard lengths or custom length sensor stems up to 6 Metres.
- Stainless steel 316 housing and wetted components.
- Suitable for gas and dust environments.
- IP68 Ingress protection.
- Reed switch or Hall Effect sensing technology.
- Voltage and current loop analogue output.
- Factory programmable set point triggers available.
- M20 and ½"NPT cable connections.
- Custom mounting options available.
- Narrow sensor stem and mounting for tanks without internal access.
- Suitable for high liquid temperatures.
- Can be specified for process temperatures down to -55°C .

Flameproof LVCS FP Continuous Level Sensor

Type	Specification	
Sensor technology	Magnetic float with reed switch or Hall Effect	Note 1
Reed switch sensing resolution Ø12mm stem Ø8mm stem	5mm 6mm	
Hall Effect sensing resolution	15mm	
Interface options: 4-20mA 0-2V 0-4V 0-10V 4-20mA Loop powered Multi interface	4 to 20mA for 10Ω to 1.2KΩ load 0 to 2.048V @ 5mA 0 to 4.096V @ 5mA 0 to 10.0V @ 5mA 4 to 20mA for 10Ω to 1.2KΩ load 4 to 20mA for 10Ω to 1.2KΩ load and 0 – 10V @ 5mA and 2 X open collector transistor	
Sensor tube and wetted materials	Stainless steel 316L	
Connection head material	Stainless steel 316	
IP rating with suitable cable gland	IP68	
Approximate weight: Ø12mm stem Ø8mm stem	1Kg+process connector + 0.5Kg/Metre 1Kg+process connector + 0.3Kg/Metre	
Float Diameter: Specific gravity Ø12mm stem Ø8mm stem	53mm : 0.65 30mm : 0.75	Other floats available
Maximum liquid temperature Standard T5rates Reed switch Standard T5 rated Hall Effect Non-standard on request	-20 to +85°C -10 to +80°C -55°C/-40°C or +125°C/+180°C	Note 2
Maximum head temperature	-55°C to +80°C for Gas hazard -40°C to +80°C for Dust hazard	Note 3
Maximum operating pressure: Standard models High pressure on request	150PSI / 10Bar standard 450PSI / 31Bar	Note 4
Thread connection-Sensor tube	½"-14 NPT	
Thread connection-Wiring port	½"-14 NPT or M20X1.5	
Connection head height	95mm	
Power supply: 4-20mA 0 to 2V 0 to 4V 0 to 10V 4-20mA Loop powered Multi interface	15 to 28Volts. Typical 24V@0.6Watts 5 to 28Volts. Typical 12V@0.25Watts 7 to 28Volts. Typical 12V@0.25Watts 14 to 28Volts. Typical 24V@0.5Watts 17 to 25Volts via current loop 8 to 25Volts. Typical 24V@0.6Watts+current loop	
Current loop output. R _{Load}	10Ω to 1.2KΩ	Note 5
Multi interface - open collector transistor	28Vdc Max. 50mA Max	

Note 1: Due to the variability of components, the output may be non-monotonic. If this could cause a problem in your application, please call our technical sales department.

Note 2: LVCS FP for liquids with maximum temperature between 85°C and 180°C or minimum temperatures below -20°C are available – please call the sales office for assistance.

Note 3: When this equipment is intended to be used in a liquid with a process temperature above 85°C it is an essential requirement that the sensor head temperature is measured to determine if the ambient air cooling is sufficient to keep the head below 80°C. See installation manual for detail.

Flameproof LVCS FP Continuous Level Sensor

Note 4: The LVCS FP sensor float and tube can withstand the stated pressure when sealed inside a tank. The connection head and resin seal inside the sensor stem must not be pressurised.

The standard zone 0 fittings are rated at 10bar, these fittings are not part of the certified flameproof seal and should not be considered as part of an explosion proof containment. Please call our technical sales department regarding sensors for liquid pressures up to 31bar.

Note 5: Maximum load resistance is determined by the formula:

$$R_{load(max)} = (\text{supply Voltage} - 2V) / 20mA.$$

At maximum specified voltage and temperature, the minimum load resistance increases to approximately 500Ω

An approximate formula is:

$$R_{load(min)} = (\text{Supply voltage}) / 20mA - (150C - (\text{Ambient temperature})) / 0.04C/\Omega$$

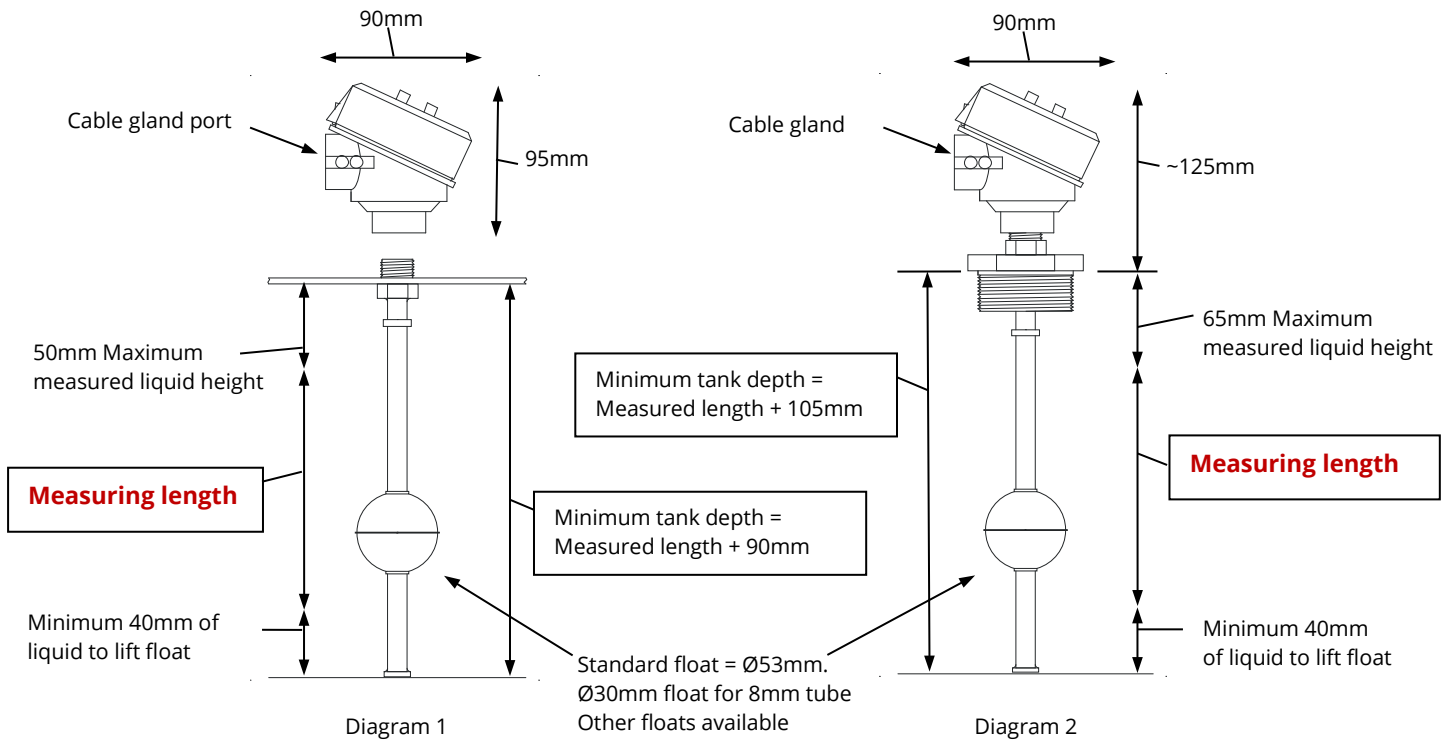

Flameproof LVCS FP Continuous Level Sensor

Ordering information

Due to the various options available please call our sales office to discuss your requirements. Options include: Probe length, interface board, Threaded mounting/seal options, Reed/Hall Effect technology, float sizes, 8 or 12mm sensor tube, cable entry thread.

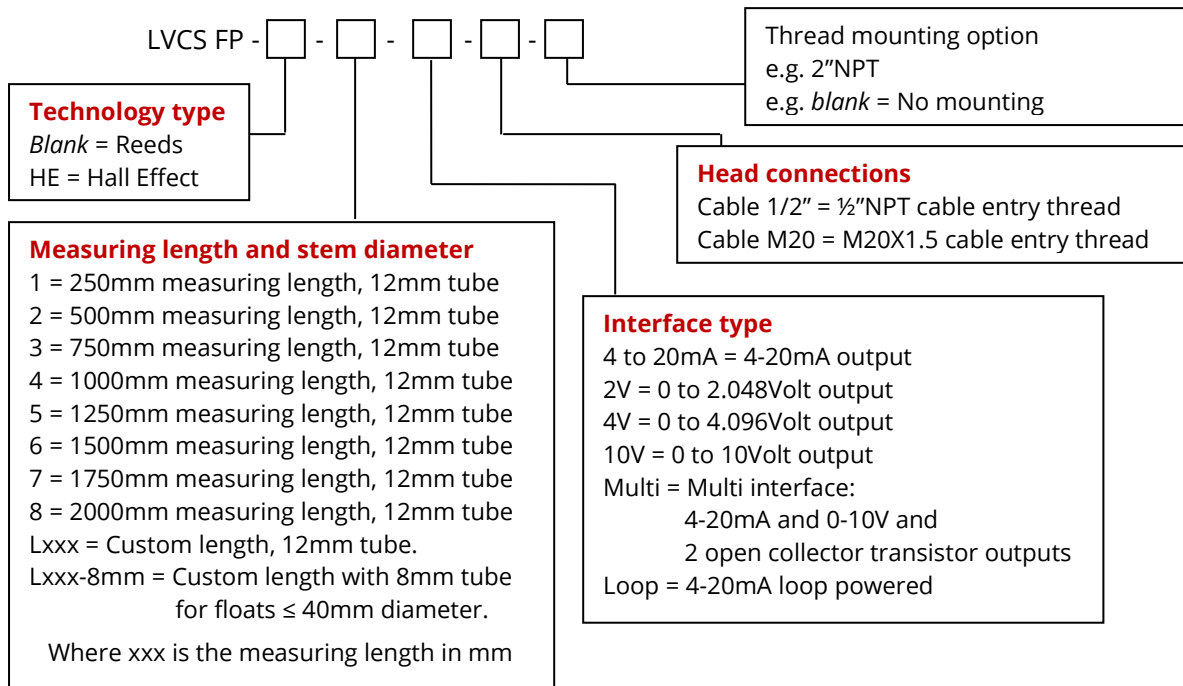

Upon receipt of the above information a drawing and Deeter part No. will be issued to identify the options selected. This part No. will be required when making your order.

Don't forget: Tank depth must be at least 90mm longer than the measuring length.

Example: LVCS FP HE-L635-loop-cable1/2"-2"BSP is a Flame proof liquid level sensor using Hall Effect technology. Measuring length =635mm, Overall sensor length =740mm using a 12mm tube. Interface is a loop powered 4-20mA board housed in a thermocouple head with 1/2"NPT port for a cable gland, and a 2"BSP pipe fitting welded to the top of the stem for mounting the sensor into a tank of liquid.

All electrical equipment should be installed by a qualified/certified electrician.

Deeter Electronics follows a policy of continual development of its products and reserves the right to change specifications and/or features without notice.

Flameproof LVCS FP Continuous Level Sensor

Identification

The LVCS FP sensors covered by this document can be identified by these labels attached to the sensor head. Both the head label and the sensor tube end stop are marked with their date of manufacture in the form of 2 letters. The S/N:xxxxxx is a unique serial No. given to each piece of equipment. The LVCS FP:xxxxxx is a 6 digit model code. The model code is also the Deeter reference number of a drawing which identifies the electrical connections and custom mechanical dimensions. A copy of this drawing should be attached to this manual. The temperature class shown here as a * will be either T5/100°C, T4/135°C or T3/200°C

Head labels

Sensors with a zone separation fitting

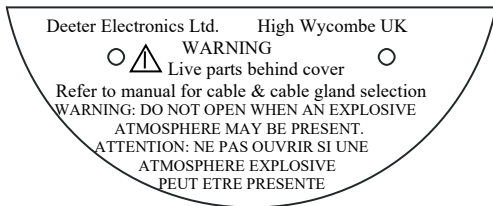
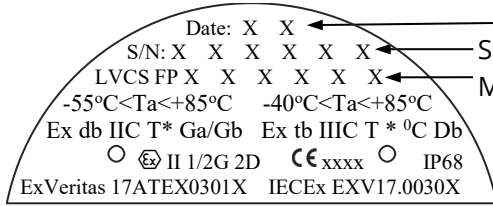
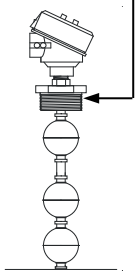

Sensors without a zone separation fitting

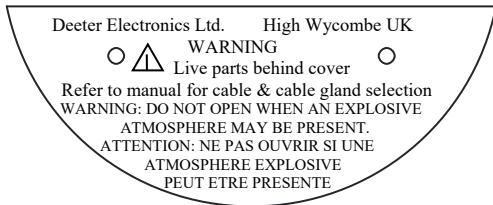
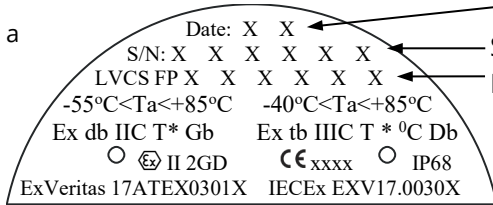
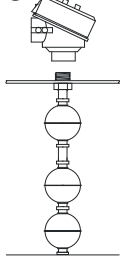

Date of manufacture
 Date: X X

First letter	Second letter
A = January	R = 2017
B = February	S = 2018
C = March	T = 2019
D = April	U = 2020
E = May	V = 2021
F = June	W = 2022
G = July	X = 2023
H = August	Y = 2024
I = September	Z = 2025
J = October	
K = November	
L = December	
Post Dec2025	
M = January	A = 2026
N = February	B = 2027
O = March	C = 2028
...	D = 2029
X = December	etc.

Flameproof LVCS FP Continuous Level Sensor

Instruction for mounting and wiring a LVCS FP

1) This document details the installation of all versions of standard Deeter LVCS FP and their optional mounting / zone seal. Separate documents are available for the LVCSi FP and single/multi point float switches.



2) Do not open the lid or disconnect any part of the sensor when an explosive atmosphere may be present.

This device must be installed in accordance with IEC/EN60079-14

3) LVCS FP without a custom mounting option can be installed by suspending the sensor over the liquid as shown in diagram 3 and 4.

Only LVCS FP with a custom mounting, as shown in diagram 5, can be installed across a Zone 0 and Zone 1 boundary. It is essential that equipment mounted across a Zone 0 and Zone 1 boundary are installed with a sufficiently tight joint in accordance with clause 4.6 of EN60079-26 to provide an IP67 seal between zones.

4) All versions of LVCS FP must be mounted vertically $\pm 5^\circ$ with the head positioned so it will not become immersed in liquid during normal operation. A LVCS FP with a liquid tight seal can be mounted from the bottom of a tank with the stem above the head if required.

The magnetic float and sensor stem must be installed away from any magnetic field or ferrous materials which could influence its operation.

Mounting and wiring must only be carried out in a safe environment.

5) All versions of LVCS FP must be mounted where the ambient temperature will allow the sensor head to cool to below 80°C . This is especially significant where the process temperature is above 85°C .

6) The standard LVCS FP sensor is supplied ready to mount through a 22.5mm hole in the top of a tank or onto a mounting bracket as shown in diagram 3. When the thickness of the tank or bracket exceeds 4mm thick ensure the head can be screwed onto the stem with a minimum of 5 revolutions and be wrench tight without gripping or being restricted by the bracket. Bracket thickness can never exceed 10mm.

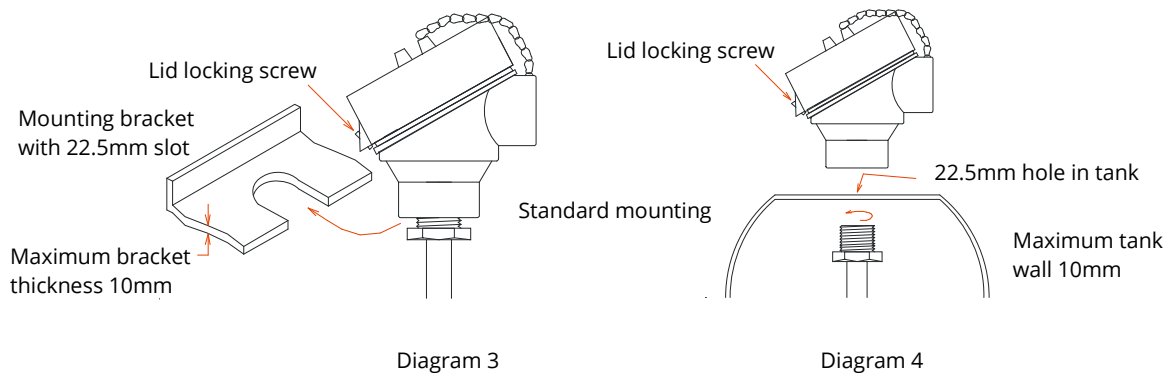

Flameproof LVCS FP Continuous Level Sensor

7) Loosen the lid locking screw and unscrew the top of the head. Detach the wires going into the sensor stem by pulling the connector off the circuit board.

Unscrew the stem from the head.

The use of a soft metal tommy bar screwed into the cable gland entry to facilitate additional leverage may be required. Care must be taken to not damage the cable entry thread by using excessive force, striking the tommy bar or using a non-threaded bar.

A 150mm long brass tommy bar is available from Deeter Electronics if required.

Remove old PTFE tape and apply several layers of new PTFE tape to the male thread. As an alternative, a non setting grease according to EN 60079-1 clause 5.1 may be used to replace the PTFE tape. Failure to apply PTFE tape or grease may lead to thread galling and irreparable damage to this thread.

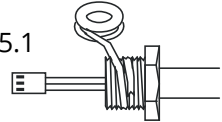

8) Mount the stem in the tank and screw the head back on top.

Clamp the head and use a 24mm spanner on the stem hexagon to tighten the joint. Do not use grips on the tube or end stop.

The head / stem joint must be tightened with a minimum of 5 revolutions of thread engagement.

Ensure the stem is tight into the head and it has not gripped the mounting bracket or tank wall.

9) LVCS FP with a custom mounting do not require the separation of the head and stem, but during installation the head/stem joint should be checked that it is secure as described above.

10) All LVCS FP with custom mounting options are supplied with a drawing to identify the supplied fitting. The supplied mounting will enable the installer to screw or clamp the sensor into place. It is not possible to install a sensor by welding as the welding process will damage the sensors internal electronics. When tightening a threaded pipe fittings as shown in diagram 5, do not use the grips on the stem or use the head as a lever, always use a spanner on the pipe fitting.

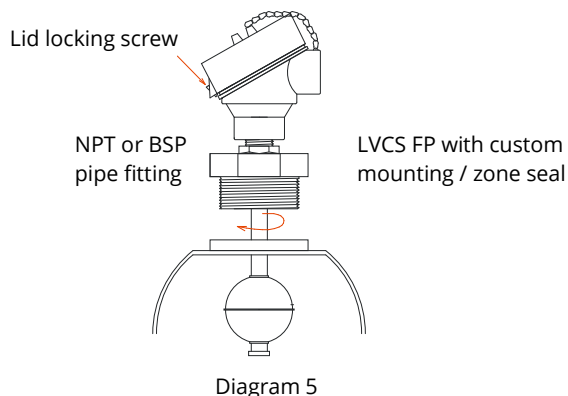

Flameproof LVCS FP Continuous Level Sensor



11) When a sensor is installed in a position where it may be exposed to excessive vibration, stress or impact from liquid bound particles. Then the sensor must be protected by additional support or deflectors as shown in diagram 7.

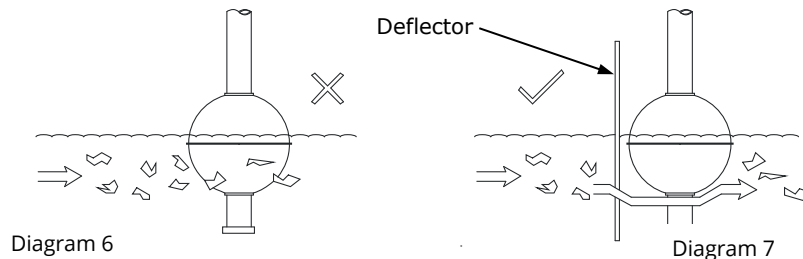

12) When this equipment is intended to be used in a liquid with a process temperature above 85°C it is an essential requirement that the sensor head temperature is measured to determine if the ambient air cooling is sufficient to keep the head below 80°C. With the sensor stem immersed to its maximum level in the process liquid at maximum temperature, a measurement of the temperature at the base of the head must be taken. Consideration of the ambient temperature during the measurement should be made and an evaluation of the maximum temperature the sensor head may reach should be recorded. Where the head temperature is expected to rise above 80°C then additional air cooling is required to keep the head below 80°C.

When the sensor is intended for use in a dust environment the above test should be carried out with a layer of dust covering the sensor head.



13) With the LVCS FP mounted in the tank the cables can be connected.

The sensor head is not normally supplied with a cable gland so the installer is free to select a suitable explosion proof gland or conduit to mate with the M20X1.5 or ½"-14NPT port in the stainless steel head.

When selecting components to attach to the LVCS FP the following conditions should be considered.



If ambient temperature around the sensor head is greater than 65°C the connecting cable and its gland or stopping box must be able to withstand the increased temperature range. These components must have a minimum temperature specification of 5°C above the maximum possible ambient temperature and have a minimum ingress protection rating of IP68.

When using conduit a stopping box must be fitted no more than 50mm from the sensor head. The stopping box and conduit must be installed in accordance with clause 13.2.2 IEC/EN60079-1.

14) A cable strain relief can be made by passing the cable through the nylon washer and fixing a cable tie tight to the cable, leaving a minimum of 70mm after the cable tie.

Flameproof LVCS FP Continuous Level Sensor



15) The connecting wires to the 4-20mA or voltage output boards must be between 16 to 22AWG (Metric capacity 1.5mm²) and with 6mm stripped ends. The earth wire should be connected to the screw point in the head using the crimp terminal provided.

EXd flameproof cable gland for enclosures with internal volume ≥ 0.5 litres and suitable for gas, zone, temperature and cable type being used. IP6x glands must be used in dust environments

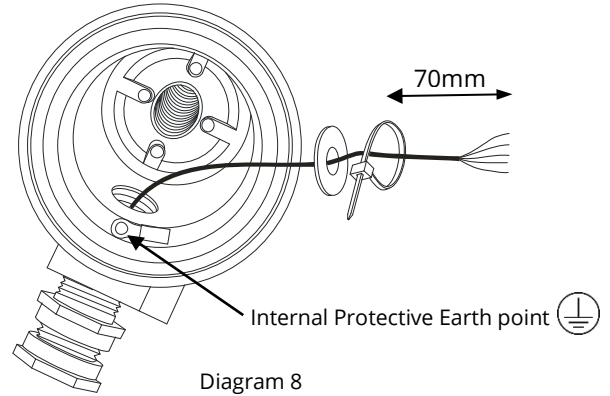

Flameproof LVCS FP Continuous Level Sensor

16) The electrical wiring required depends on the electrical output of your LVCS FP sensor.

16a) **LVCS FP with powered 4-20mA output**

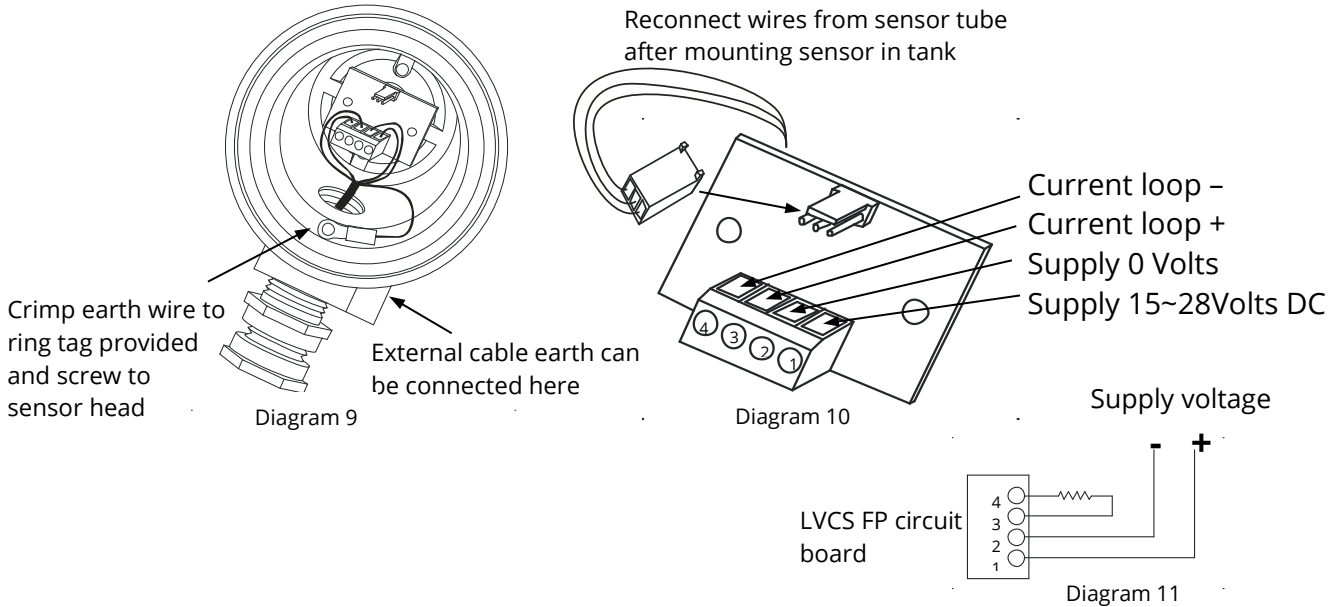

16b) **LVCS FP with 0 to 2Volt, 0 to 4Volt or 0 to 10Volt output**

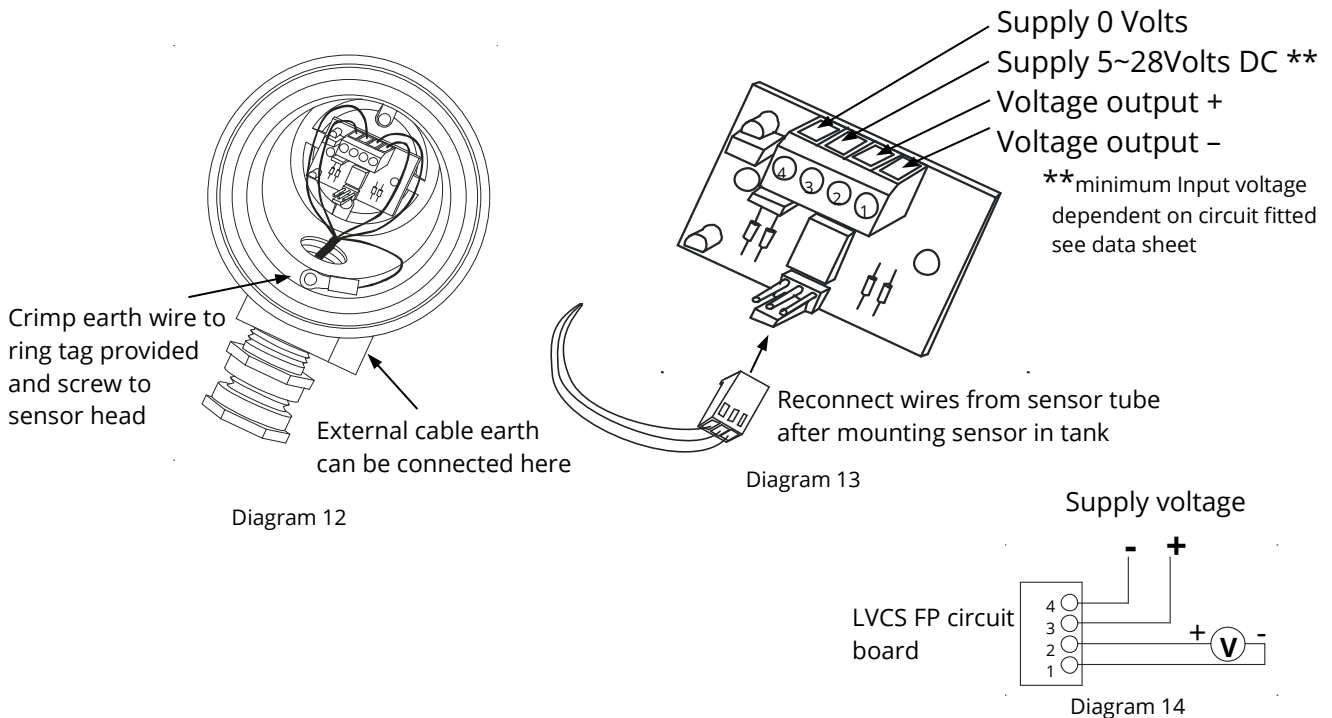

Flameproof LVCS FP Continuous Level Sensor

16c) LVCS FP with Multi Interface

The Multi Interface board is capable of simultaneously outputting a voltage and current loop signals and also operating two open collector transistors at pre programmed set points. Outputs that are not required may be left unconnected.

set points are programmed at manufacture.

Default set points are:

Digital output #1 is On with level below 10%, Off above 20%

Digital output #2 is On with level above 90%, Off below 80%

Other thresholds can be set on request.

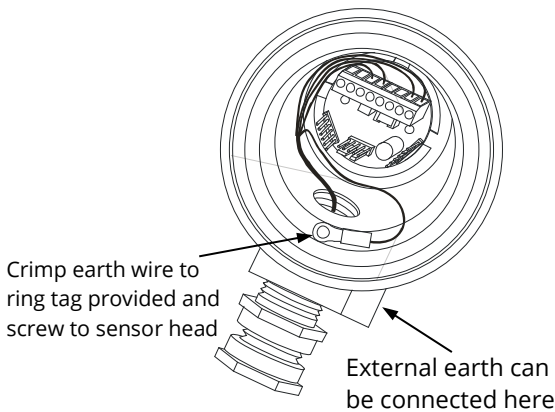
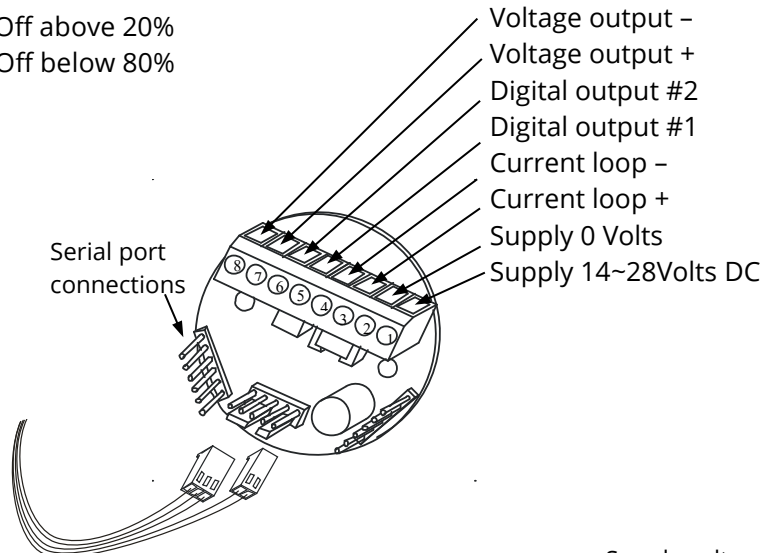
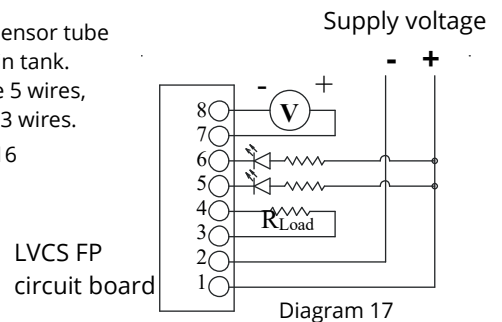

Diagram 15



Reconnect wires from sensor tube after mounting sensor in tank.
Hall Effect sensors have 5 wires,
reed sensors have 2 or 3 wires.

Diagram 16



Flameproof LVCS FP Continuous Level Sensor



16d) LVCS FP with Loop powered 4-20mA output

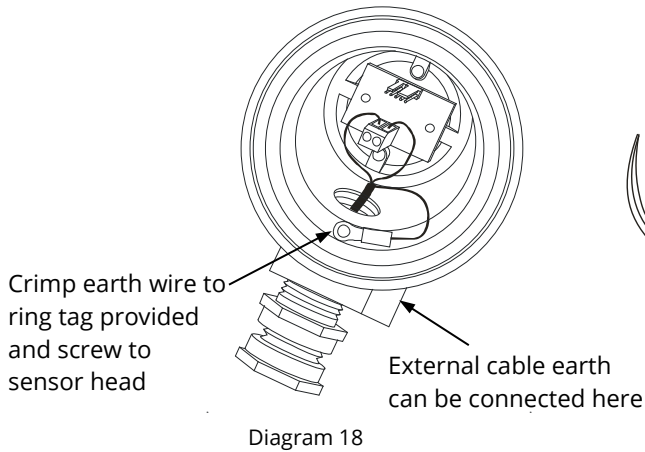

Reconnect wires from sensor tube after mounting sensor in tank.
Hall Effect sensors have 5 wires,
reed sensors have 3 wires.

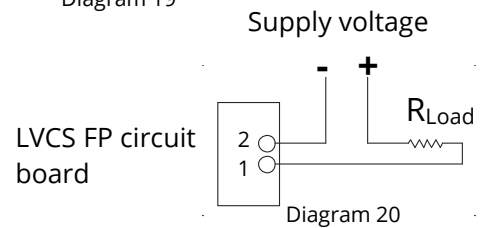
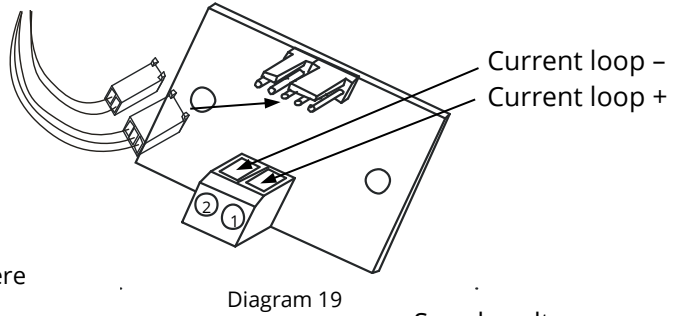

17) The electrical supply to the sensor must be connected through a protection device to limit excess current should a fault occur. A fast blow 250mA fuse can be used to limit the maximum current drawn. The fuse must be placed in a position where it protects the cable and the sensor should a fault occur.

18) After connecting the earth, supply and output wires screw the lid down hand-tight, keep applying torque by hand until the lid cannot be turned any further. Tighten the lid-locking screw so the lid cannot be accidentally removed.

The electrical connections to a safe power supply and monitoring device depends on the output type of your LVCS FP sensor.

Flameproof LVCS FP Continuous Level Sensor

Maintenance/Repair

Any repairs or replacements parts must be carried out by the manufacturers or their appointed repair agent.

Sensors with a long unsupported stem or in contact with fast moving liquids should include a maintenance plan to inspect the welded joints for fracture and fatigue.

A sensor stem immersed in hot or aggressive chemicals should be checked for corrosion on a regular basis with special attention to the stem end stop weld.

Where additional air cooling was required in the installation process, the effectiveness of the cooling should be checked as described in section 12.

Only the LVCS FP multi interface board contains a fuse. This can be replaced with a 500mA 2.69X2.69X6.1mm anti-surge fuse.

The three flameproof threads as show in diagram 21, and there interconnecting parts must be clean and free from dust or debris before assembly.

Damage to flameproof threads must not be Repaired - contact Deeter Electronics for replacements.

The Oring under the head cover should be inspected for damage.

Remove dust from devices with large mounting flange or plug.

Use a damp cloth for cleaning to avoid electric charging hazard.

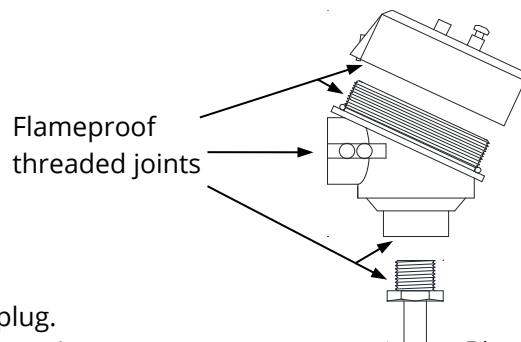

Diagram 21

Storage

Store in dry conditions without strong magnetic influence. Protect the float from impact.

Transport

Transport in rigid container with sensor head supported. Support sensor stem evenly and limit the float from moving along the stem. Protect float sides from impact by supporting sensor stem in the middle of the packing. Remove packing material from around the float to avoid secondary impact to the float. The float must not be used to support the stem.

1 EU - Type Examination Certificate

2 Equipment intended for use in Potentially Explosive Atmospheres Directive 2014/34/EU

3 Certificate Number: ExVeritas 17ATEX0301X Issue: 2

4 Equipment: Liquid Vertical Continuous Sensor, Flameproof (LVCS FP) Float Switch,
Flameproof (F/S FP) Liquid Vertical Continuous Sensor with integrated
display, Flameproof (LVCSi FP)

5 Manufacturer: Deeter Electronics Ltd

6 Address: Deeter House, Valley Road, Hughenden Valley, High Wycombe, Bucks,
HP14 4LW, UK

7 This equipment and any acceptable variation thereto are specified in the schedule to this certificate and the documents therein referred to.

8 ExVeritas, Notified Body number 2804 in accordance with Article 17 of the Council Directive 2014/34/EU of 26 February 2014, certifies that this equipment or protective system has been found to comply with the Essential Health and Safety Requirements relating to design and construction of equipment and protective systems for use in potentially explosive atmospheres given in Annex II to the Directive

9 Compliance with the applicable Essential Health and Safety Requirements has been assured by compliance with the following Standards and section 16 of this certificate:

BS EN IEC 60079-0: 2018 BS EN 60079-1:2014 BS EN 60079-26:2015
BS EN 60079-31:2014

10 If the sign "X" is placed after the certificate number, it indicates that the equipment is subject to special conditions for safe use specified in the schedule to this certificate.

11 This EU-Type Examination Certificate relates only to the design, construction, examination and tests of the specified equipment or protective system in accordance to the Directive 2014/34/EU. Further requirements of the Directive apply to the manufacturing process and supply of this equipment or protective system. These are not covered by this certificate.

12 The marking of the equipment shall include the following:

 II 1/2G (or 2G) Ex db IIC T* Ga/Gb (or Gb) -55°C ≤ T_{amb} ≤ +85°C

 II 2 D Ex tb IIIC T* Db -40°C ≤ T_{amb} ≤ +85°C

On behalf of ExVeritas



Peter Lauritzen
Managing Director

Schedule

13 Description of Equipment or Protective System

The LVCS FP (Liquid Vertical Continuous Sensor) and F/S FP (Float Switch) are liquid level sensors with either a continuous analogue or switching output. The equipment comprises of a flameproof, component certified instrument housing with stainless steel level guide which is threaded into the housing. The level guide consists of either an 8mm or 12mm stainless steel tube which contains the sensing electronics. The instrument housing is used for termination and mounting of optional PCB's, depending on the communication and I/O's required. The level guides can be various lengths and are mounted with up to seven stainless steel floats, each containing a magnetic ring. The equipment can be supplied with an optional threaded adaptor or equivalent gas tight seal for mounting across a boundary of two hazardous area zones.

When connected to process temperatures above 85°C, the instrument housing must be sufficiently cooled to keep it below 80°C, as detailed in the manufacturer's instructions.

The following temperature classes are applicable based on the process temperature which the equipment is connected to:

Model	Level guide length (mm)	Sensing device	Input/Output Options	Process Temperature and associated temperature class	Cable Entry sizes
LVCS	100 to 6000	Reed switch or Hall effect	Optional PCB's for various input/outputs	≤85°C (T5) (T100°C) ≤125°C (T4) (T135°C) ≤180°C (T3) (T200°C)	M20 x 1.5 or ½" NPT
F/S	60 to 6000	Reed switch	Between 1 to 7 I/O float switches, direct output	≤85°C (T5) (T100°C) ≤125°C (T4) (T135°C) ≤190°C (T3) (T200°C)	M20 x 1.5 or ½" NPT

The following ratings are applicable:

- 0 to 2v output. 5 to 25vdc input @ 25mA
- 0 to 4 v output. 7 to 25Vdc input @ 25mA
- 0 to 10v output. 14 to 28vdc input @ 35mA
- 8 to 28vdc input @30mA Multi interface 4-20mA, voltage output
- 0-50VDC 0-240V AC 1Amp (F/S FP reed switch only)

13.1 Details of changes

The following changes are incorporated in Issue 1 of the certificate:

- Update to the latest edition of EN 60079-0 as detailed on page 1 of the certificate.
- Inclusion of the LVCSi range of vertical liquid level sensors with integrated display and optional temperature sensor.

Model	Level guide length (mm)	Sensing device	Input/Output Options	Process Temperature and associated temperature class	Cable Entry sizes
LVCSi	100 to 6000	Reed switch or Hall effect. Optional temperature sensor	Optional PCB's for various input/outputs	≤85°C (T5) (T100°C) ≤125°C (T4) (T135°C) ≤180°C (T3) (T200°C)	2 off M20 x 1.5 or 2 off ½" NPT

10-30Vdc @ 100mA

The marking of the LVCSi range shall include the following:

 II 1/2G (or 2G) Ex db IIC T* Ga/Gb (or Gb) -40°C ≤ T_{amb} ≤+85°C

Certificate: ExVeritas 17ATEX0301X

Issue 2

This certificate may only be reproduced in its entirety and without any change, schedule included.

For help or assistance relating to this certificate, contact info@exveritas.com.

ExVeritas ApS, Severinsmindevej 6, 4420 Regstrup, Denmark.

ExVeritas® is a registered trademark, unauthorised use will lead to prosecution.

Schedule

 II 2 D Ex tb IIIC T* Db $-40^{\circ}\text{C} \leq T_{\text{amb}} \leq +85^{\circ}\text{C}$

13.2 Details of changes

- Transfer of the certificate from ExVeritas UK, Notified Body number 2585 to ExVeritas Denmark, Notified Body number 2804. Certificate number remains unchanged.

14 Descriptive Documents

14.1 Associated Report and Certificate History:

Report Number	Cert Issue Date	Issue	Comment
R1288/A/1	14/12/2017	0	Initial issue of the Prime Certificate
R2757/A/1	24/09/2020	1	Issue of the first variation.
EXV4121A	15/09/2022	2	Issue of the second variation.

14.2 Compliance Drawings:

Number	Date	Issue	Description
D 600779	29/11/2017	2	LVCS FP all versions Sheet 1 of 2
D 600779_2	29/11/2017	3	LVCS FP all versions Sheet 2 of 2
D 600781	29/11/2017	2	F/S FP all versions Sheet 1 of 2
D 600781_2	29/11/2017	3	F/S FP all versions Sheet 2 of 2
Dwg 950553	11/8/2017	2	Adaptor 1/2" NPT Long thread to 12mm Sheet 1 of 2
Dwg 950568	11/8/2017	2	Adaptor 1/2" NPT long thread to 8mm Sheet 1 of 2
D600850	11 th March 2020	Rev 1	LVCSi FP all versions (Sheets 1 to 2)
-	17/09/2020	-	LVCSi FP manual

15 Conditions of Certification

15.1 Special Conditions for Safe Use

- When intended to be operating with process temperatures above 85°C, the sensor head shall be sufficiently cooled to keep it below 80°C. See installation manual for details.
- The LVCSi may be operated with process temperatures down to -55°C, when used at temperatures below -40°C, the sensor head shall be kept at a temperature of at least -40°C. See installation manual for details.
- Refer to manual for cable entry thread size and type.

15.2 Conditions for Use

- The LVCS FP and F/S FP range of sensors are subject to a routine tests on production in accordance with clause 16 of EN/IEC 60079-1 to a pressure of at least 57.2 Bar.
- The level guide assembly of the LVCSi FP shall be subject to a routine over pressure test in accordance with clause 16 of EN/IEC 60079-1 to a pressure of at least 17.2 Bar.
- The equipment covered under this certificate incorporates previously certified components, it is therefore the responsibility of the manufacturer to monitor the status of the certification of these components and inform ExVeritas of any changes that may affect the explosion safety design of their products.

Certificate: ExVeritas 17ATEX0301X

Issue 2

This certificate may only be reproduced in its entirety and without any change, schedule included.

For help or assistance relating to this certificate, contact info@exveritas.com.

ExVeritas ApS, Severinsmindevej 6, 4420 Regstrup, Denmark.

ExVeritas® is a registered trademark, unauthorised use will lead to prosecution.



Schedule

16 Essential Health and Safety Requirements

Essential Health and Safety Requirements are addressed by the standards listed in section 9 and where required the report listed in section 14.1

The manufacturer shall inform the Notified Body of any modifications to the design of the product described by this schedule.

Certificate: ExVeritas 17ATEX0301X

Issue 2

This certificate may only be reproduced in its entirety and without any change, schedule included.

For help or assistance relating to this certificate, contact info@exveritas.com.

ExVeritas ApS, Severinsmindevej 6, 4420 Regstrup, Denmark.

ExVeritas® is a registered trademark, unauthorised use will lead to prosecution.



IECEX Certificate of Conformity

INTERNATIONAL ELECTROTECHNICAL COMMISSION IEC Certification System for Explosive Atmospheres

for rules and details of the IECEx Scheme visit www.iecex.com

Certificate No.: **IECEX EXV 17.0030X** Page 1 of 6 [Certificate history:](#)
Issue 0 (2017-12-19)

Status: **Current** Issue No: 1

Date of Issue: 2020-09-25

Applicant: **Deeter Electronics Limited**
Deeter House, Valley Road
Hughenden Valley
High Wycombe
Bucks
HP14 4LW
United Kingdom

Equipment: **Liquid Vertical Continuous Sensor, Flameproof (LVCS FP) and Float Switch, Flameproof (F/S FP)**

Optional accessory:

Type of Protection: **Equipment protection by flameproof enclosure "d", Equipment with EPL Ga and Equipment dust ignition protection by enclosure "t"**

Marking: Ex db IIC T* Ga/Gb or Ex db IIC T* Gb $-50^{\circ}\text{C} \leq \text{Tamb} \leq +85^{\circ}\text{C}$
Ex tb IIIC *°C Db $-40^{\circ}\text{C} \leq \text{Tamb} \leq +85^{\circ}\text{C}$

Approved for issue on behalf of the IECEx
Certification Body:

S Clarke CEng MSc MIET

Position:

Certification Manager

Signature:
(for printed version)

Date:

1. This certificate and schedule may only be reproduced in full.
2. This certificate is not transferable and remains the property of the issuing body.
3. The Status and authenticity of this certificate may be verified by visiting www.iecex.com or use of this QR Code.



Certificate issued by:

ExVeritas Limited
Units 16-18 Abenbury Way
Wrexham Ind. Est.
Wrexham LL 139UZ
United Kingdom





IECEX Certificate of Conformity

Certificate No.: **IECEX EXV 17.0030X**

Page 2 of 6

Date of issue: 2020-09-25

Issue No: 1

Manufacturer: **Deeter Electronics Limited**
Deeter House, Valley Road
Hughenden Valley
High Wycombe, Bucks, HP14 4LW
United Kingdom

Additional
manufacturing
locations:

This certificate is issued as verification that a sample(s), representative of production, was assessed and tested and found to comply with the IEC Standard list below and that the manufacturer's quality system, relating to the Ex products covered by this certificate, was assessed and found to comply with the IECEx Quality system requirements. This certificate is granted subject to the conditions as set out in IECEx Scheme Rules, IECEx 02 and Operational Documents as amended

STANDARDS :

The equipment and any acceptable variations to it specified in the schedule of this certificate and the identified documents, was found to comply with the following standards

IEC 60079-0:2017 Explosive atmospheres - Part 0: Equipment - General requirements
Edition:7.0

IEC 60079-1:2014-06 Explosive atmospheres - Part 1: Equipment protection by flameproof enclosures "d"
Edition:7.0

IEC 60079-26:2014-10 Explosive atmospheres – Part 26: Equipment with Equipment Protection Level (EPL) Ga
Edition:3.0

IEC 60079-31:2013 Explosive atmospheres - Part 31: Equipment dust ignition protection by enclosure "t"
Edition:2

This Certificate **does not** indicate compliance with safety and performance requirements other than those expressly included in the Standards listed above.

TEST & ASSESSMENT REPORTS:

A sample(s) of the equipment listed has successfully met the examination and test requirements as recorded in:

Test Reports:

[GB/EXV/ExTR17.0029/00](#)

[GB/EXV/ExTR20.0072/00](#)

Quality Assessment Report:

[GB/SIR/QAR12.0004/07](#)



IECEx Certificate of Conformity

Certificate No.: **IECEx EXV 17.0030X**

Page 3 of 6

Date of issue: 2020-09-25

Issue No: 1

EQUIPMENT:

Equipment and systems covered by this Certificate are as follows:

The LVCS FP (Liquid Vertical Continuous Sensor) and F/S FP (Float Switch) are liquid level sensors with either a continuous analogue or switching output. The equipment comprises of a flameproof, component certified instrument housing with stainless steel level guide which is threaded into the housing. The level guide consists of either an 8mm or 12mm stainless steel tube which contains the sensing electronics. The instrument housing is used for termination and mounting of optional PCB's, depending on the communication and I/O's required. The level guides can be various lengths and are mounted with up to seven stainless steel floats, each containing a magnetic ring. The equipment can be supplied with an optional threaded adaptor or equivalent gas tight seal for mounting across a boundary of two hazardous area zones.

When connected to process temperatures above 85°C, the instrument housing must be sufficiently cooled to keep it below 80°C, as detailed in the manufacturer's instructions.

The following temperature classes are applicable based on the process temperature which the equipment is connected to:

Model	Level guide length (mm)	Sensing device	Input/Output Options	Process Temperature and associated temperature class	Cable Entry sizes
LVCS	100 to 6000	Reed switch or Hall effect	Optional PCB's for various input/outputs	≤85°C (T5) (T100°C) ≤125°C (T4) (T135°C) ≤180°C (T3) (T200°C)	M20 x 1.5 or ½" NPT
F/S	60 to 6000	Reed switch or Hall effect	Between 1 to 7 I/O float switches, direct output	≤85°C (T5) (T100°C) ≤125°C (T4) (T135°C) ≤190°C (T3) (T200°C)	M20 x 1.5 or ½" NPT

SPECIFIC CONDITIONS OF USE: YES as shown below:

- When intended to be operating with process temperatures above 85°C, the sensor head shall be sufficiently cooled to keep it below 80°C. See installation manual for details.
- The LVCSi may be operated with process temperatures down to -55°C, when used at temperatures below -40°C, the sensor head shall be kept at a temperature of at least -40°C. See installation manual for details.
- Refer to manual for cable entry thread size and type.



IECEx Certificate of Conformity

Certificate No.: **IECEx EXV 17.0030X**

Page 4 of 6

Date of issue: 2020-09-25

Issue No: 1

Equipment (continued):

The following ratings are applicable:

- 0 to 2v output. 5 to 25vdc input @ 25mA
- 0 to 4 v output. 7 to 25Vdc input @ 25mA
- 0 to 10v output. 14 to 28vdc input @ 35mA
- 8 to 28vdc input @30mA Multi interface 4-20mA, voltage output
- 0-50VDC 0-240V AC 1Amp (F/S FP reed switch only)

Routine Tests:

- The LVCS FP and F/S FP range of sensors are subject to a routine tests on production in accordance with clause 16 of EN/IEC 60079-1 to a pressure of at least 57.2 Bar.
- The equipment covered under this certificate incorporates previously certified components, it is therefore the responsibility of the manufacturer to monitor the status of the certification of these components and inform ExVeritas of any changes that may affect the explosion safety design of their products.
- The level guide assembly of the LVCSi shall be subject to a routine over pressure test in accordance with clause 16 of EN/IEC 60079-1 to a pressure of at least 16.3 Bar.



IECEX Certificate of Conformity

Certificate No.: **IECEX EXV 17.0030X**

Page 5 of 6

Date of issue: 2020-09-25

Issue No: 1

DETAILS OF CERTIFICATE CHANGES (for issues 1 and above)

The following changes are introduced:

- Update to IEC 60079-0 Edition 7.0
- Inclusion of the LVCSi range Vertical Liquid Level Sensor with integrated display and optional temperature sensor.

Model	Level guide length (mm)	Sensing device	Input/Output Options	Process Temperature and associated temperature class	Cable Entry sizes
LVCSi	100 to 6000	Reed switch or Hall effect, Optional temperature sensor	Optional PCB's for various input/outputs	≤85°C (T5) (T100°C) ≤125°C (T4) (T135°C) ≤180°C (T3) (T200°C)	2 off M20 x 1.5 or 2 off 1/2" NPT

Rating - 10-30Vdc @ 100mA

The marking of the LVCSi range shall include the following:

Ex db IIC T* Ga/Gb (or Gb) -40°C ≤ Tamb ≤ +85°C

Ex tb IIIC T* Db -40°C ≤ Tamb ≤ +85°C



IECEx Certificate of Conformity

Certificate No.: **IECEx EXV 17.0030X**

Page 6 of 6

Date of issue: 2020-09-25

Issue No: 1

**Additional information:
Technical Documents:**

Title:	Drawing No.:	Rev. Level:	Date:
LVCSi FP all versions Sheets 1 to 2)	D600850	Rev 1	11 th March 2020
LVCSi FP manual	-	-	17/09/2020