

DZB Intrinsic Safety Zener Barrier

The DZB Zener Barrier is a range of Intrinsic Safety Zener Barriers for the safe application of intrinsically safe equipment in an explosive atmosphere. The DZB limits the energy transferred to the hazardous area to a safe level incapable of igniting the explosive atmosphere.



Features include:

- ATEX/ IECEx Ex ia approved
- 77 different variations
- 1, 2 and 3 channel options available

The DZB is available with 1, 2 or 3 channels, 7 reference voltages and 5 maximum current rating. Always check the product label to confirm the correct model parameters have been selected and which type of hazardous location the barrier is suitable to protect. Table 1 identifies which model is suitable for the different levels of gas, dust and mining hazards.

Safety

- 1) Installation of this product must be conducted in accordance with EN60079-14 and the control drawing identified on the product label or referenced in Table 1 below.
- 2) If the DZB is not installed according to the control drawing the safety protection may be impaired.
- 3) The green and yellow wire must be connected to a suitable ground to ensure a low resistance path to earth.

DZB Intrinsic Safety Zener Barrier

Installation:

The DZB can be installed on to a 35mm DIN-Rail or direct to a wall. The DZB may be mounted in any orientation where the screw terminals can be easily viewed for reliable connection. It is normal practice to orientate the barrier with the earth wire and hazardous area terminals below the safe area terminals. The DZB can be mounted indoors or outdoors where its environments can be controlled to ensure barrier is not operated outside the -40°C to $+60^{\circ}\text{C}$ temperature range (T_a).

The DZB has an IP20 rating which requires the installation location to be protected from water and dust. Safety critical equipment should be located in a place where unauthorised access is prevented.

Direct mount: The black plastic clips on both sides of the DZB base can be pushed outwards to expose a screw hole. A click can be heard as the clip moves from DIN rail to direct mount position. The two holes can accept a 4mm or No.8 screw.

DIN Rail: With the black plastic clips on both sides of the DZB base pushed towards the enclosure's centre notch, the DZB is ready to mount onto a 35mm wide, 7.5mm high DIN Rail. Hook the one edge of a black plastic clip over the top edge of the DIN Rail before pressing the DZB case firmly towards the rail and down until the lower clip snaps over the DIN Rail. To release from the DIN Rail a small flat blade screw driver can be used to lever the black plastic clip away from the DIN Rail until the enclosure can be pulled up and off the rail.

Earth Connection: The DZB must be connected to Earth (also known as Protective Earth). The earth connection for the entire intrinsically safe circuit must not exceed 1.0 Ohm. To facilitate this low resistance connection the DZB incorporates a 4mm^2 green and yellow insulated earth wire. The standard DZB earth wire is 150mm long and terminated with a bootlace ferrule. This earth wire must be connected with sufficiently low resistance to 'Earth' in accordance with EN 60079-14.

Additional earth wires may be connected using one or more of the earth screw terminals.

Ambient temperature: $-40^{\circ}\text{C} \leq T_{\text{amb}} \leq +60^{\circ}\text{C}$

Humidity: 0-95% Non-Condensing

Pollution Degree: 2

IP rating: IP20

Altitude: 5000 metres

Dimensions: Length 99mm, Width 23mm, Height 112mm

Special Instructions for Safe Use

The device must be installed and maintained according to EN / IEC 60079-14, EN / IEC 60079-17 and EN / IEC 60079-25.

If the device is installed with one or more additional barriers then the outputs must be galvanically separated from each other to prevent the potential association of parallel sources being connected together.

The device must only be installed in a non-hazardous area (safe area), or installed so that is covered by another type of protection (e.g. an ex 'd' enclosure).

The intrinsically safe circuits are not segregated from the ground circuit, all the limiting circuits are based on Zener barriers and therefore there is no insulation between the intrinsically safe circuits and the grounding circuit.

DZB Intrinsic Safety Zener Barrier

Identification:

The DZB has two side labels, one top label and four terminal labels. Both side labels have an area to display product specific information. The labels are coloured red and blue to assist in the easy identification of miss-placed wires. Wires connecting the barrier to the hazardous zone must connect to the terminals on the blue side marked Hazardous Area or Hazloc.

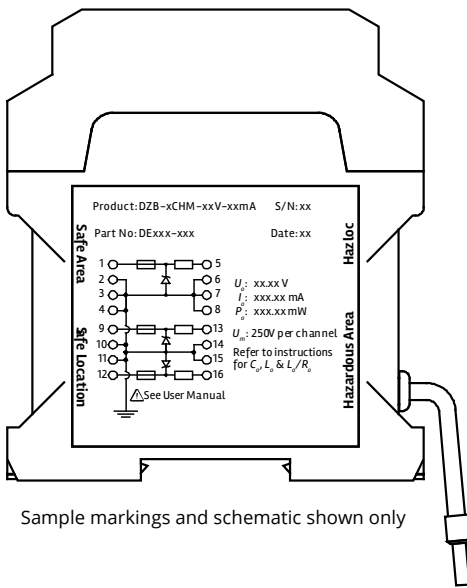

Sample markings and schematic shown only

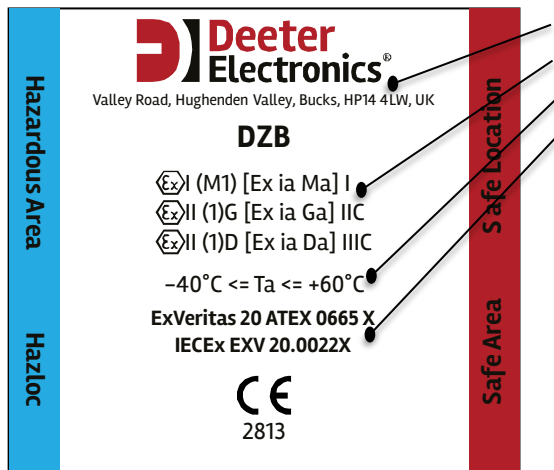
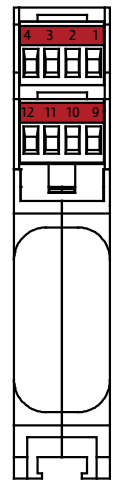
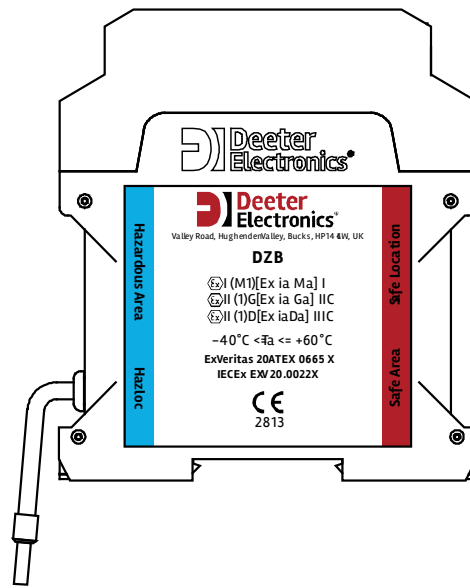
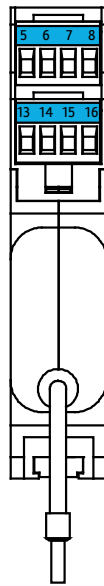

Sample markings shown only

Manufacturers name and address
ATEX Markings (3 versions)
Ambient temperature range
Certificate No. of Ex approval

DZB Intrinsic Safety Zener Barrier

Product model / Ordering code. See below

Deeter Electronics part No.

Schematic layout (3 versions)

Intrinsically Safe Parameters

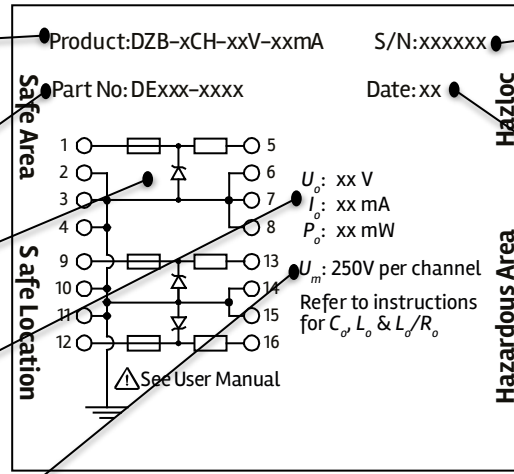

Sample schematic shown only

Unique serial No. S/N:xxxxxx

Date of manufacture*

| First letter | Second letter |
|---------------|---------------|
| A = January | U = 2020 |
| B = February | V = 2021 |
| C = March | W = 2022 |
| D = April | X = 2023 |
| E = May | Y = 2024 |
| F = June | Z = 2025 |
| G = July | |
| H = August | |
| I = September | |
| J = October | |
| K = November | |
| L = December | |

*From 2026, the first letter of the date code (referencing the month of manufacture) will re-index beginning with M for January, N for February, O for March etc.

The second letter (referencing the year of manufacture) will start again at A for 2026, B for 2027, C for 2028 etc.

Maximum voltage that can be applied to the 'Safe side' terminals before protection is compromised.

Ordering Code:

The DZB is available in single voltage and multi-voltage variants.
Single Voltage Ordering Code:



Fuse rating: 50, 80, 100, 125 or 160mA

Nominal Voltage: 6, 10, 12, 18, 24, 28 or 36Vdc

Number of channels: 1, 2 or 3

*not all combinations are available, refer to the options table for details.

Multi Voltage Ordering Codes:



24/5-4/20, 24/5 or 24/10



24/5/5 or 24/10/10

| Ordering Code | Channel 1 Nominal Voltage | Channel 1 Fuse rating | Channel 2 Nominal Voltage | Channel 2 Fuse rating | Channel 3 Nominal Voltage | Channel 3 Fuse rating |
|--------------------|---------------------------|-----------------------|---------------------------|-----------------------|---------------------------|-----------------------|
| DZB-2CHM-24/5-4/20 | 24V | 50mA | 5V | 40mA | N/A | N/A |
| DZB-2CHM-24/5 | 24V | 50mA | 5V | 40mA | N/A | N/A |
| DZB-2CHM-24/10 | 24V | 50mA | 10V | 40mA | N/A | N/A |
| DZB-3CHM-24/5/5 | 24V | 50mA | 5V | 40mA | 5V | 40mA |
| DZB-3CHM-24/10/10 | 24V | 50mA | 10V | 40mA | 10V | 40mA |

DZB Intrinsic Safety Zener Barrier

Wiring:

Refer to the Control Drawing for Entity Parameters and Hazardous Area Location.
Installation must be made according to EN 60079-14

The 4mm² earth wire must be connected to a high-integrity protective earth point. It is also normal practice to include a 1.5mm² additional earth wire from one of the DZB earth screw terminals to a separate protective earth point. The earth screw terminals are 2, 3, 4, 6, 7, 8, 10, 11, 14 and 15.
The DZB does NOT provide an earth connection through the DIN-rail mount.

The DZB has 16 rising clamp screw terminals for 1.5mm² wire (28–15 AWG)

Single channel schematic and overview diagram. Refer to associated Control Drawing for detail.

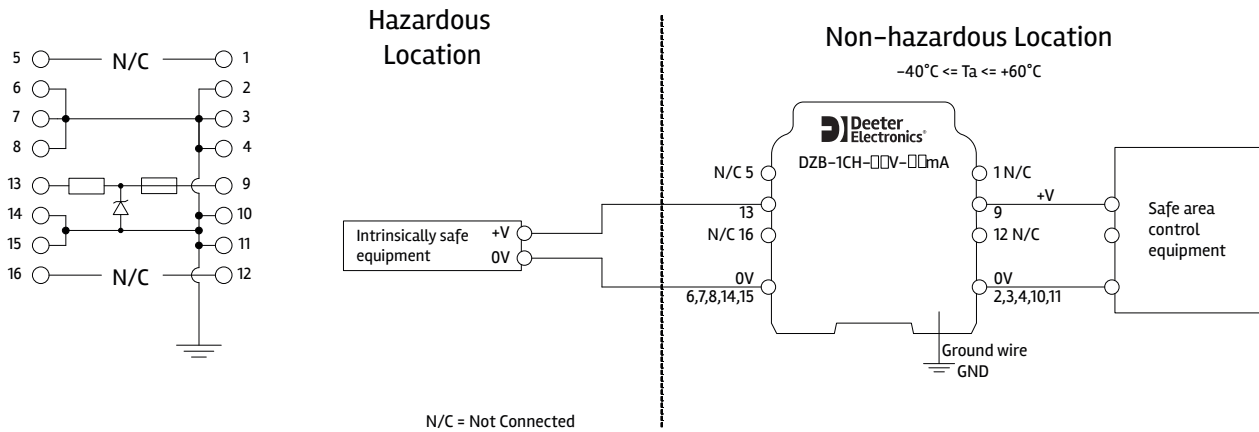

Two channel schematic and overview diagram. Refer to associated Control Drawing for detail.

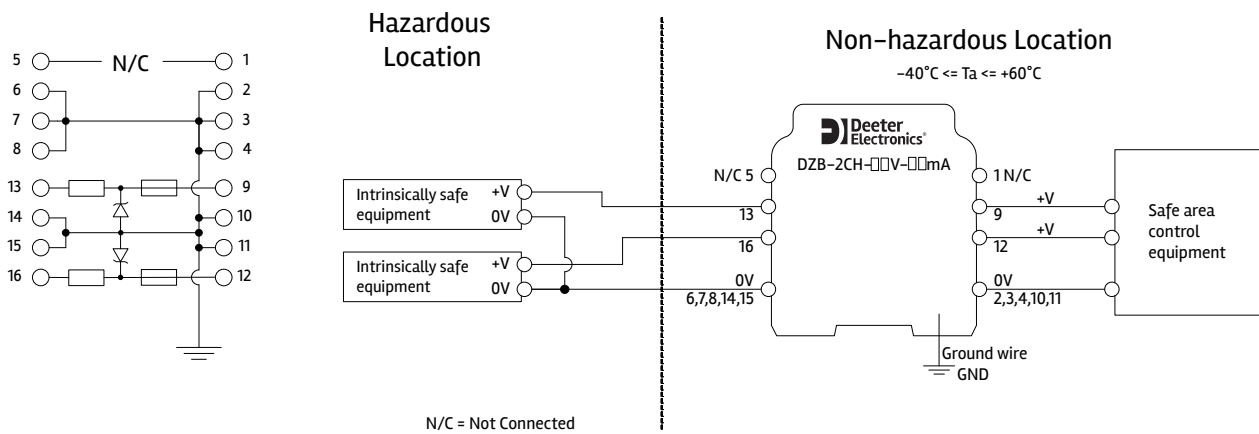

DZB Intrinsic Safety Zener Barrier

Three channel schematic and overview diagram. Refer to associated Control Drawing for detail.

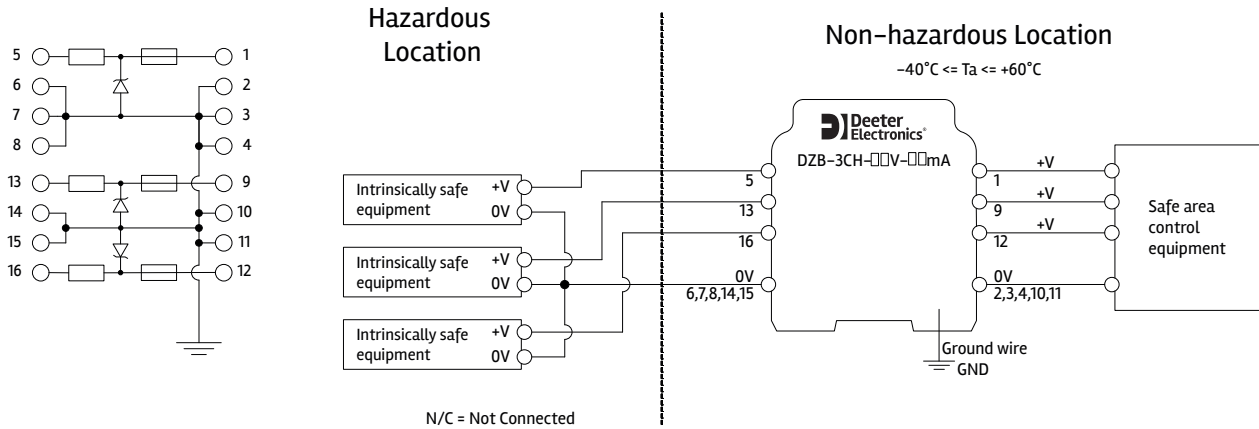

Servicing:



























The DZB has no serviceable parts and requires no adjustments.

The DZB cannot be repaired by the user and must be replaced with an equivalent certified product.

Warning: Substitution of components is not permitted. Any attempt to open or repair this barrier will invalidate intrinsic safety.

DZB Intrinsic Safety Zener Barrier

Options table and ATEX/IECEx Markings





















| 1 Channel | | | | | | |
|-------------------|----------------------------|----------|-----|------------|--|-----------------|
| Ordering Code | Gas/Dust Group Suitability | | | | ATEX/IECEx marking | Control Drawing |
| | IIC/IIIC | IIB/IIIC | IIA | Mining (I) | | |
| DZB-1CH-6V-50mA | ✓ | ✓ | ✓ | ✓ |  I (M1) [Ex ia Ma] I  II (1)G [Ex ia Ga] IIC  II (1)D [Ex ia Da] IIIC | D600807 |
| DZB-1CH-6V-80mA | ✓ | ✓ | ✓ | ✓ | | |
| DZB-1CH-6V-100mA | ✓ | ✓ | ✓ | ✓ | | |
| DZB-1CH-6V-125mA | ✓ | ✓ | ✓ | ✓ | | |
| DZB-1CH-6V-160mA | ✓ | ✓ | ✓ | ✓ | | |
| DZB-1CH-10V-50mA | ✓ | ✓ | ✓ | ✓ |  I (M1) [Ex ia Ma] I  II (1)G [Ex ia Ga] IIC  II (1)D [Ex ia Da] IIIC | D600808 |
| DZB-1CH-10V-80mA | ✓ | ✓ | ✓ | ✓ | | |
| DZB-1CH-10V-100mA | ✓ | ✓ | ✓ | ✓ | | |
| DZB-1CH-10V-125mA | ✓ | ✓ | ✓ | ✓ | | |
| DZB-1CH-10V-160mA | ✓ | ✓ | ✓ | ✓ | | |
| DZB-1CH-12V-50mA | ✓ | ✓ | ✓ | ✓ |  I (M1) [Ex ia Ma] I  II (1)G [Ex ia Ga] IIC  II (1)D [Ex ia Da] IIIC | D600809 |
| DZB-1CH-12V-80mA | ✓ | ✓ | ✓ | ✓ | | |
| DZB-1CH-12V-100mA | ✓ | ✓ | ✓ | ✓ | | |
| DZB-1CH-12V-125mA | ✓ | ✓ | ✓ | ✓ | | |
| DZB-1CH-12V-160mA | ✓ | ✓ | ✓ | ✓ | | |
| DZB-1CH-18V-50mA | ✓ | ✓ | ✓ | ✓ |  I (M1) [Ex ia Ma] I  II (1)G [Ex ia Ga] IIC  II (1)D [Ex ia Da] IIIC | D600810 |
| DZB-1CH-18V-80mA | ✓ | ✓ | ✓ | ✓ | | |
| DZB-1CH-18V-100mA | ✓ | ✓ | ✓ | ✓ | | |
| DZB-1CH-18V-125mA | ✓ | ✓ | ✓ | ✓ | | |
| DZB-1CH-18V-160mA | ✓ | ✓ | ✓ | ✓ | | |
| DZB-1CH-24V-50mA | ✓ | ✓ | ✓ | ✓ |  I (M1) [Ex ia Ma] I  II (1)G [Ex ia Ga] IIC  II (1)D [Ex ia Da] IIIC | D600811 |
| DZB-1CH-24V-80mA | ✓ | ✓ | ✓ | ✓ | | |
| DZB-1CH-24V-100mA | ✓ | ✓ | ✓ | ✓ | | |
| DZB-1CH-24V-125mA | ✓ | ✓ | ✓ | ✓ | | |
| DZB-1CH-24V-160mA | ✗ | ✓ | ✓ | ✓ | | |
| DZB-1CH-28V-50mA | ✓ | ✓ | ✓ | ✓ |  I (M1) [Ex ia Ma] I  II (1)G [Ex ia Ga] IIC  II (1)D [Ex ia Da] IIIC | D600813 |
| DZB-1CH-28V-80mA | ✓ | ✓ | ✓ | ✓ | | |
| DZB-1CH-28V-100mA | ✗ | ✓ | ✓ | ✓ |  I (M1) [Ex ia Ma] I  II (1)G [Ex ia Ga] IIB  II (1)D [Ex ia Da] IIIC | D600814 |
| DZB-1CH-28V-125mA | ✗ | ✓ | ✓ | ✓ | | |
| DZB-1CH-36V-50mA | ✓ | ✓ | ✓ | ✓ |  I (M1) [Ex ia Ma] I  II (1)G [Ex ia Ga] IIC  II (1)D [Ex ia Da] IIIC | D600815 |
| DZB-1CH-36V-80mA | ✗ | ✓ | ✓ | ✓ | | |
| DZB-1CH-36V-100mA | ✗ | ✓ | ✓ | ✓ |  I (M1) [Ex ia Ma] I  II (1)G [Ex ia Ga] IIB  II (1)D [Ex ia Da] IIIC | D600816 |
| | | | | | | |







DZB Intrinsic Safety Zener Barrier

| 2 Channel | | | | | | |
|-------------------|----------------------------|----------|-----|------------|--|-----------------|
| Ordering Code | Gas/Dust Group Suitability | | | | ATEX/IECEX marking | Control Drawing |
| | IIC/IIIC | IIB/IIIC | IIA | Mining (I) | | |
| DZB-2CH-6V-50mA | ✓ | ✓ | ✓ | ✓ | ⚠ I (M1) [Ex ia Ma] I ⚠ II (1)G [Ex ia Ga] IIC ⚠ II (1)D [Ex ia Da] IIIC | D600817 |
| DZB-2CH-6V-80mA | ✓ | ✓ | ✓ | ✓ | | |
| DZB-2CH-6V-100mA | ✓ | ✓ | ✓ | ✓ | | |
| DZB-2CH-6V-125mA | ✓ | ✓ | ✓ | ✓ | | |
| DZB-2CH-6V-160mA | ✓ | ✓ | ✓ | ✓ | | |
| DZB-2CH-10V-50mA | ✓ | ✓ | ✓ | ✓ | ⚠ I (M1) [Ex ia Ma] I ⚠ II (1)G [Ex ia Ga] IIC ⚠ II (1)D [Ex ia Da] IIIC | D600818 |
| DZB-2CH-10V-80mA | ✓ | ✓ | ✓ | ✓ | | |
| DZB-2CH-10V-100mA | ✓ | ✓ | ✓ | ✓ | | |
| DZB-2CH-10V-125mA | ✓ | ✓ | ✓ | ✓ | | |
| DZB-2CH-10V-160mA | ✓ | ✓ | ✓ | ✓ | | |
| DZB-2CH-12V-50mA | ✓ | ✓ | ✓ | ✓ | ⚠ I (M1) [Ex ia Ma] I ⚠ II (1)G [Ex ia Ga] IIC ⚠ II (1)D [Ex ia Da] IIIC | D600819 |
| DZB-2CH-12V-80mA | ✓ | ✓ | ✓ | ✓ | | |
| DZB-2CH-12V-100mA | ✓ | ✓ | ✓ | ✓ | | |
| DZB-2CH-12V-125mA | ✓ | ✓ | ✓ | ✓ | | |
| DZB-2CH-18V-50mA | ✓ | ✓ | ✓ | ✓ | ⚠ I (M1) [Ex ia Ma] I ⚠ II (1)G [Ex ia Ga] IIC ⚠ II (1)D [Ex ia Da] IIIC | D600820 |
| DZB-2CH-18V-80mA | ✓ | ✓ | ✓ | ✓ | | |
| DZB-2CH-18V-100mA | ✓ | ✓ | ✓ | ✓ | | |
| DZB-2CH-24V-50mA | ✓ | ✓ | ✓ | ✓ | ⚠ I (M1) [Ex ia Ma] I ⚠ II (1)G [Ex ia Ga] IIC ⚠ II (1)D [Ex ia Da] IIIC | D600821 |
| DZB-2CH-28V-50mA | ✗ | ✓ | ✓ | ✓ | ⚠ I (M1) [Ex ia Ma] I ⚠ II (1)G [Ex ia Ga] IIB ⚠ II (1)D [Ex ia Da] IIIC | D600822 |
| DZB-2CH-36V-50mA | ✗ | ✓ | ✓ | ✓ | ⚠ I (M1) [Ex ia Ma] I ⚠ II (1)G [Ex ia Ga] IIB ⚠ II (1)D [Ex ia Da] IIIC | D600823 |

| 2 Channel Mixed Voltage | | | | | | |
|-------------------------|----------------------------|----------|-----|------------|--|-----------------|
| Ordering Code | Gas/Dust Group Suitability | | | | ATEX/IECEX marking | Control Drawing |
| | IIC/IIIC | IIB/IIIC | IIA | Mining (I) | | |
| DZB-2CHM-24/5-4/20 | ✓ | ✓ | ✓ | ✓ | ⚠ I (M1) [Ex ia Ma] I ⚠ II (1)G [Ex ia Ga] IIC ⚠ II (1)D [Ex ia Da] IIIC | D600825 |
| DZB-2CHM-24/5 | ✓ | ✓ | ✓ | ✓ | ⚠ I (M1) [Ex ia Ma] I ⚠ II (1)G [Ex ia Ga] IIC ⚠ II (1)D [Ex ia Da] IIIC | D600826 |
| DZB-2CHM-24/10 | ✓ | ✓ | ✓ | ✓ | ⚠ I (M1) [Ex ia Ma] I ⚠ II (1)G [Ex ia Ga] IIC ⚠ II (1)D [Ex ia Da] IIIC | D600827 |

DZB Intrinsic Safety Zener Barrier

| 3 Channel | | | | | | |
|-------------------|----------------------------|----------|-----|------------|--|-----------------|
| Ordering Code | Gas/Dust Group Suitability | | | | ATEX/IECEX marking | Control Drawing |
| | IIC/IIIC | IIB/IIIC | IIA | Mining (I) | | |
| DZB-3CH-6V-50mA | ✓ | ✓ | ✓ | ✓ |    | D600833 |
| DZB-3CH-6V-80mA | ✓ | ✓ | ✓ | ✓ | | |
| DZB-3CH-6V-100mA | ✓ | ✓ | ✓ | ✓ | | |
| DZB-3CH-6V-125mA | ✓ | ✓ | ✓ | ✓ | | |
| DZB-3CH-6V-160mA | ✓ | ✓ | ✓ | ✓ | | |
| DZB-3CH-10V-50mA | ✓ | ✓ | ✓ | ✓ |    | D600834 |
| DZB-3CH-10V-80mA | ✓ | ✓ | ✓ | ✓ | | |
| DZB-3CH-10V-100mA | ✓ | ✓ | ✓ | ✓ | | |
| DZB-3CH-10V-125mA | ✓ | ✓ | ✓ | ✓ | | |
| DZB-3CH-10V-160mA | ✓ | ✓ | ✓ | ✓ | | |
| DZB-3CH-12V-50mA | ✓ | ✓ | ✓ | ✓ |    | D600835 |
| DZB-3CH-12V-80mA | ✓ | ✓ | ✓ | ✓ | | |
| DZB-3CH-12V-100mA | ✓ | ✓ | ✓ | ✓ | | |
| DZB-3CH-12V-125mA | ✓ | ✓ | ✓ | ✓ | | |
| DZB-3CH-18V-50mA | ✓ | ✓ | ✓ | ✓ |    | D600836 |
| DZB-3CH-18V-80mA | ✓ | ✓ | ✓ | ✓ | | |
| DZB-3CH-18V-100mA | ✓ | ✓ | ✓ | ✓ | | |
| DZB-3CH-24V-50mA | ✗ | ✓ | ✓ | ✓ |    | D600837 |
| DZB-3CH-28V-50mA | ✗ | ✓ | ✓ | ✓ |    | D600838 |
| DZB-3CH-36V-50mA | ✗ | ✗ | ✓ | ✓ |   | D600839 |

| 3 Channel Mixed Voltage | | | | | | |
|-------------------------|----------------------------|----------|-----|------------|--|-----------------|
| Ordering Code | Gas/Dust Group Suitability | | | | ATEX/IECEX marking | Control Drawing |
| | IIC/IIIC | IIB/IIIC | IIA | Mining (I) | | |
| DZB-3CHM-24/5/5 | ✓ | ✓ | ✓ | ✓ |    | D600828 |
| DZB-3CHM-24/10/10 | ✓ | ✓ | ✓ | ✓ |    | D600829 |

DZB Intrinsic Safety Zener Barrier

| | |
|---------------------|---|
| Dimensions | 99mm x 23mm x 112mm |
| Weight | 290g (approx.) |
| Housing Material | ABS (UL94-V0) |
| Connections | Rising clamp screw terminals for 1.5mm ² wire (28 to 15 AWG) |
| Mounting | Top hat 35mm DIN rail |
| Ambient Temperature | Ta = -40°C to +60°C |
| ATEX Certificate | ExVeritas 20 ATEX 0665 X |
| IECEX Certificate | IECEX EXV 20.0022X |
| ATEX Standards | EN 60079-0:2018 EN 60079-11:2012 |
| IECEX Standards | IEC 60079-0:2017 IEC 60079-11:2011 |

1 EU - Type Examination Certificate

2 Equipment intended for use in Potentially Explosive Atmospheres Directive 2014/34/EU

3 Certificate Number: ExVeritas 20ATEX0665X Issue: 2

4 Equipment: Deeter Zener Barrier

5 Manufacturer: Deeter Electronics

6 Address: Deeter House, Valley Road, Hughenden Valley, Bucks, HP14 4LW, UK

7 This equipment and any acceptable variation thereto are specified in the schedule to this certificate and the documents therein referred to.

8 ExVeritas, Notified Body number 2804 in accordance with Article 17 of the Council Directive 2014/34/EU of 26 February 2014, certifies that this equipment or protective system has been found to comply with the Essential Health and Safety Requirements relating to design and construction of equipment and protective systems for use in potentially explosive atmospheres given in Annex II to the Directive

9 Compliance with the applicable Essential Health and Safety Requirements has been assured by compliance with the following Standards and section 16 of this certificate:

EN IEC 60079-0: 2018

EN 60079-11:2012

10 If the sign "X" is placed after the certificate number, it indicates that the equipment is subject to special conditions for safe use specified in the schedule to this certificate.

11 This EU-Type Examination Certificate relates only to the design, construction, examination and tests of the specified equipment or protective system in accordance to the Directive 2014/34/EU. Further requirements of the Directive apply to the manufacturing process and supply of this equipment or protective system. These are not covered by this certificate.

12 The marking of the equipment shall be marked according to the markings listed in part 13.

Schedule

13 Description of Equipment or Protective System

The DZB (Deeter Zener Barrier) is designed for fixed installation into a DIN Rail with a rating of $U_m = 250$ V. The barrier has one, two, or three channels which have identical electrical parameters for Current, Voltage, and Power on each channel. There are also a select few variants which have 'mixed' channels where each of the two or three channels may have a differing electrical parameters to the alternate channels. The product types are differentiated using the following product code:

Product name: DZB – □ CH □ – □□V – □□ mA

The product name uses the character '□' to reveal the barrier characteristics following from left to right:



- CH □ Number of channels (Prefix is either 1, 2 or 3 and/or with the postfix 'M' indicating mixed voltages/currents on individual channels)
- Vdc Potential difference (Volts) per individual channel
- mA Current in milliampere per individual channel

Given that each barrier has up to 3 channels, and also given the electrical characteristics the entity parameters in each case is calculated considering the channels combined. When using and installing the device the parameters must be considered in consonance with IEC 60079-11 Cl, 10.1.5.2. where:



1. The external circuit contains no combined lumped inductance 'Li' and capacitance 'Ci' greater than 1% of the values in the table below or;
2. The inductance and capacitance are distributed as in a cable or;
3. The external circuit contains either only lumped inductance or lumped capacitance in combination with a cable.

In all other situations e.g. the external circuit combined lumped inductance and lumped capacitance, up to 50% of each of the L_o and C_o values is allowed.



Excluding the models listed below, all the models are marked as:

-  I (M1) [Ex ia Ma] I
-  II (1)G [Ex ia Ga] IIC
-  II (1)D [Ex ia Da] IIIC

The models DZB-1CH-24V-160mA, DZB-1CH-28V-100mA, DZB-1CH-28V-125mA, DZB-1CH-36V-80mA, DZB-1CH-36V-100mA, DZB-2CH-28V-50mA, DZB-2CH-36V-50mA, DZB-3CH-24V-50mA and DZB-3CH-28V-50mA are marked as:

-  I (M1) [Ex ia Ma] I
-  II (1)G [Ex ia Ga] IIB
-  II (1)D [Ex ia Da] IIIC

The model DZB-3CH-36V-50mA is marked as:

-  I (M1) [Ex ia Ma] I
-  II (1)G [Ex ia Ga] IIA

1, 2, and 3 channel variants (same currents and voltages per channel), entity parameters calculated with the channels associated in parallel:

Table key: * = Not suitable for IIC, ** = Not suitable for IIB

Schedule

| Barrier Type | Uo (V) | Io (mA) | Po (mW) | Lo/Ro (mH/Ω) IIC | Lo/Ro (mH/Ω) IIB | Lo/Ro (mH/Ω) IIA | Lo/Ro (mH/Ω) I |
|-------------------|--------|---------|---------|------------------|------------------|------------------|----------------|
| DZB-1CH-6V-50mA | 6.3 | 63.64 | 100.24 | 0.35 | 1.41 | 2.83 | 4.65 |
| DZB-1CH-6V-80mA | 6.3 | 84.85 | 133.64 | 0.26 | 1.06 | 2.12 | 3.49 |
| DZB-1CH-6V-100mA | 6.3 | 102.64 | 161.66 | 0.21 | 0.87 | 1.75 | 2.88 |
| DZB-1CH-6V-125mA | 6.3 | 124.78 | 196.53 | 0.18 | 0.72 | 1.44 | 2.37 |
| DZB-1CH-6V-160mA | 6.3 | 163.18 | 257.01 | 0.13 | 0.55 | 1.1 | 1.81 |
| DZB-1CH-10V-50mA | 10.5 | 53.04 | 139.23 | 0.25 | 1.02 | 2.04 | 3.35 |
| DZB-1CH-10V-80mA | 10.5 | 85.54 | 224.55 | 0.15 | 0.63 | 1.26 | 2.07 |
| DZB-1CH-10V-100mA | 10.5 | 106.07 | 278.44 | 0.12 | 0.51 | 1.02 | 1.67 |
| DZB-1CH-10V-125mA | 10.5 | 129.35 | 339.55 | 0.1 | 0.41 | 0.83 | 1.37 |
| DZB-1CH-10V-160mA | 10.72 | 164.07 | 439.71 | 0.08 | 0.32 | 0.64 | 1.06 |
| DZB-1CH-12V-50mA | 12.6 | 57.86 | 182.26 | 0.19 | 0.78 | 1.56 | 2.56 |
| DZB-1CH-12V-80mA | 12.6 | 79.55 | 250.59 | 0.14 | 0.56 | 1.13 | 1.86 |
| DZB-1CH-12V-100mA | 12.6 | 106.07 | 334.13 | 0.1 | 0.42 | 0.85 | 1.39 |
| DZB-1CH-12V-125mA | 12.6 | 127.28 | 400.94 | 0.08 | 0.35 | 0.7 | 1.16 |
| DZB-1CH-12V-160mA | 12.6 | 163.18 | 514.02 | 0.06 | 0.27 | 0.55 | 0.9 |
| DZB-1CH-18V-50mA | 18.9 | 53.04 | 250.62 | 0.14 | 0.56 | 1.13 | 1.86 |
| DZB-1CH-18V-80mA | 18.9 | 79.55 | 375.88 | 0.09 | 0.37 | 0.75 | 1.24 |
| DZB-1CH-18V-100mA | 18.9 | 104.9 | 495.66 | 0.07 | 0.28 | 0.57 | 0.94 |
| DZB-1CH-18V-125mA | 18.9 | 127.28 | 601.4 | 0.05 | 0.23 | 0.47 | 0.77 |
| DZB-1CH-18V-160mA | 18.9 | 153.96 | 727.47 | 0.04 | 0.19 | 0.39 | 0.64 |
| DZB-1CH-24V-50mA | 25.2 | 54.16 | 341.21 | 0.1 | 0.41 | 0.83 | 1.36 |
| DZB-1CH-24V-80mA | 25.2 | 70.71 | 445.48 | 0.07 | 0.31 | 0.63 | 1.04 |
| DZB-1CH-24V-100mA | 25.2 | 106.07 | 668.25 | 0.05 | 0.21 | 0.42 | 0.69 |
| DZB-1CH-24V-125mA | 25.8 | 118.46 | 764.07 | 0.04 | 0.18 | 0.37 | 0.61 |
| DZB-1CH-24V-160mA | 25.8 | 158.91 | 1024.97 | (*) | 0.13 | 0.27 | 0.45 |
| DZB-1CH-28V-50mA | 29.4 | 53.04 | 389.85 | 0.09 | 0.36 | 0.72 | 1.19 |
| DZB-1CH-28V-80mA | 29.4 | 82.5 | 606.38 | 0.05 | 0.23 | 0.46 | 0.76 |
| DZB-1CH-28V-100mA | 31.5 | 106.07 | 835.31 | (*) | 0.17 | 0.34 | 0.55 |
| DZB-1CH-28V-125mA | 31.5 | 144.63 | 1138.97 | (*) | 0.12 | 0.24 | 0.4 |
| DZB-1CH-36V-50mA | 37.8 | 57.86 | 546.78 | 0.06 | 0.26 | 0.52 | 0.85 |
| DZB-1CH-36V-80mA | 37.8 | 79.55 | 751.75 | (*) | 0.18 | 0.37 | 0.62 |
| DZB-1CH-36V-100mA | 37.8 | 106.07 | 1002.37 | (*) | 0.14 | 0.28 | 0.46 |
| DZB-2CH-6V-50mA | 6.3 | 127.28 | 200.47 | 0.35 | 1.41 | 2.83 | 4.65 |
| DZB-2CH-6V-80mA | 6.3 | 169.7 | 267.28 | 0.26 | 1.06 | 2.12 | 3.49 |
| DZB-2CH-6V-100mA | 6.3 | 212.13 | 334.11 | 0.21 | 0.85 | 1.7 | 2.79 |
| DZB-2CH-6V-125mA | 6.3 | 265.16 | 417.63 | 0.17 | 0.68 | 1.36 | 2.23 |
| DZB-2CH-6V-160mA | 6.3 | 318.19 | 501.15 | 0.14 | 0.56 | 1.13 | 1.86 |
| DZB-2CH-10V-50mA | 10.5 | 106.07 | 278.44 | 0.25 | 1.02 | 2.04 | 3.35 |
| DZB-2CH-10V-80mA | 10.5 | 171.07 | 449.06 | 0.15 | 0.63 | 1.26 | 2.07 |
| DZB-2CH-10V-100mA | 10.5 | 207.97 | 545.93 | 0.13 | 0.52 | 1.04 | 1.7 |
| DZB-2CH-10V-125mA | 10.5 | 271.96 | 713.9 | 0.09 | 0.39 | 0.79 | 1.3 |
| DZB-2CH-10V-160mA | 10.72 | 328.13 | 879.39 | 0.08 | 0.32 | 0.64 | 1.06 |
| DZB-2CH-12V-50mA | 12.6 | 115.71 | 364.49 | 0.19 | 0.78 | 1.56 | 2.56 |
| DZB-2CH-12V-80mA | 12.6 | 155.22 | 488.95 | 0.14 | 0.58 | 1.16 | 1.9 |
| DZB-2CH-12V-100mA | 12.6 | 205.28 | 646.64 | 0.1 | 0.43 | 0.87 | 1.44 |
| DZB-2CH-12V-125mA | 12.6 | 249.56 | 786.12 | 0.09 | 0.36 | 0.72 | 1.18 |
| DZB-2CH-18V-50mA | 18.9 | 106.07 | 501.19 | 0.14 | 0.56 | 1.13 | 1.86 |
| DZB-2CH-18V-80mA | 18.9 | 159.1 | 751.75 | 0.09 | 0.37 | 0.75 | 1.24 |

Certificate: ExVeritas 20ATEX0665X

Issue 2

This certificate may only be reproduced in its entirety and without any change, schedule included.

 For help or assistance relating to this certificate, contact info@exveritas.com.

ExVeritas ApS, Severinsmindevej 6, 4420 Regstrup, Denmark.

ExVeritas® is a registered trademark, unauthorised use will lead to prosecution.

Schedule

| Barrier Type | U _o (V) | I _o (mA) | P _o (mW) | Lo/Ro (mH/Ω) IIC | Lo/Ro (mH/Ω) IIB | Lo/Ro (mH/Ω) IIA | Lo/Ro (mH/Ω) I |
|-------------------|-----------------------|------------------------|------------------------|------------------------|------------------------|------------------------|----------------------|
| DZB-2CH-18V-100mA | 18.9 | 209.8 | 991.31 | 0.07 | 0.28 | 0.57 | 0.94 |
| DZB-2CH-24V-50mA | 25.2 | 106.07 | 668.25 | 0.1 | 0.42 | 0.85 | 1.39 |
| DZB-2CH-28V-50mA | 29.4 | 109.99 | 808.43 | (*) | 0.35 | 0.7 | 1.15 |
| DZB-2CH-36V-50mA | 37.8 | 115.71 | 1093.46 | (*) | 0.26 | 0.52 | 0.85 |
| DZB-3CH-6V-50mA | 6.3 | 190.91 | 300.69 | 0.35 | 1.41 | 2.83 | 4.65 |
| DZB-3CH-6V-80mA | 6.3 | 254.55 | 400.92 | 0.26 | 1.06 | 2.12 | 3.49 |
| DZB-3CH-6V-100mA | 6.3 | 318.19 | 501.15 | 0.21 | 0.85 | 1.7 | 2.79 |
| DZB-3CH-6V-125mA | 6.3 | 397.73 | 626.43 | 0.17 | 0.68 | 1.36 | 2.23 |
| DZB-3CH-6V-160mA | 6.3 | 477.28 | 751.72 | 0.14 | 0.56 | 1.13 | 1.86 |
| DZB-3CH-10V-50mA | 10.5 | 159.1 | 417.64 | 0.25 | 1.02 | 2.04 | 3.35 |
| DZB-3CH-10V-80mA | 10.5 | 256.6 | 673.58 | 0.15 | 0.63 | 1.26 | 2.07 |
| DZB-3CH-10V-100mA | 10.5 | 311.95 | 818.87 | 0.13 | 0.52 | 1.04 | 1.7 |
| DZB-3CH-10V-125mA | 10.5 | 407.93 | 1070.82 | 0.09 | 0.39 | 0.79 | 1.3 |
| DZB-3CH-10V-160mA | 10.72 | 492.2 | 1319.1 | 0.08 | 0.32 | 0.64 | 1.06 |
| DZB-3CH-12V-50mA | 12.6 | 173.56 | 546.72 | 0.19 | 0.78 | 1.56 | 2.56 |
| DZB-3CH-12V-80mA | 12.6 | 232.82 | 733.39 | 0.14 | 0.58 | 1.16 | 1.9 |
| DZB-3CH-12V-100mA | 12.6 | 307.92 | 969.95 | 0.1 | 0.43 | 0.87 | 1.44 |
| DZB-3CH-12V-125mA | 12.6 | 374.34 | 1179.18 | 0.09 | 0.36 | 0.72 | 1.18 |
| DZB-3CH-18V-50mA | 18.9 | 159.1 | 751.75 | 0.14 | 0.56 | 1.13 | 1.86 |
| DZB-3CH-18V-80mA | 18.9 | 238.64 | 1127.58 | 0.09 | 0.37 | 0.75 | 1.24 |
| DZB-3CH-18V-100mA | 18.9 | 314.69 | 1486.92 | 0.07 | 0.28 | 0.57 | 0.94 |
| DZB-3CH-24V-50mA | 25.2 | 159.1 | 1002.33 | (*) | 0.42 | 0.85 | 1.39 |
| DZB-3CH-28V-50mA | 29.4 | 164.99 | 1212.68 | (*) | 0.35 | 0.7 | 1.15 |
| DZB-3CH-36V-50mA | 37.8 | 173.56 | 1640.15 | (**) | (**) | 0.52 | 0.85 |

| Barrier Type | Co (μF) IIC | Co (μF) IIB | Co (μF) IIA | Co (μF) I | Lo (mH) IIC | Lo (mH) IIB | Lo (mH) IIA | Lo (mH) I |
|-------------------|----------------|----------------|----------------|--------------|----------------|----------------|----------------|--------------|
| DZB-1CH-6V-50mA | 31.000 | 720.000 | 1000.000 | 1000.000 | 8.77 | 35.11 | 70.23 | 115.22 |
| DZB-1CH-6V-80mA | 31.000 | 720.000 | 1000.000 | 1000.000 | 4.93 | 19.75 | 39.50 | 64.81 |
| DZB-1CH-6V-100mA | 31.000 | 720.000 | 1000.000 | 1000.000 | 3.37 | 13.50 | 27.00 | 44.29 |
| DZB-1CH-6V-125mA | 31.000 | 720.000 | 1000.000 | 1000.000 | 2.28 | 9.13 | 18.26 | 29.97 |
| DZB-1CH-6V-160mA | 31.000 | 720.000 | 1000.000 | 1000.000 | 1.33 | 5.34 | 10.68 | 17.52 |
| DZB-1CH-10V-50mA | 2.410 | 16.800 | 75.000 | 95.000 | 12.63 | 50.55 | 101.10 | 165.88 |
| DZB-1CH-10V-80mA | 2.410 | 16.800 | 75.000 | 95.000 | 4.85 | 19.43 | 38.87 | 63.77 |
| DZB-1CH-10V-100mA | 2.410 | 16.800 | 75.000 | 95.000 | 3.16 | 12.64 | 25.28 | 41.47 |
| DZB-1CH-10V-125mA | 2.410 | 16.800 | 75.000 | 95.000 | 2.12 | 8.50 | 17.00 | 27.89 |
| DZB-1CH-10V-160mA | 2.140 | 15.000 | 66.000 | 80.000 | 1.32 | 5.28 | 10.56 | 17.33 |
| DZB-1CH-12V-50mA | 1.150 | 7.400 | 27.000 | 32.000 | 10.62 | 42.48 | 84.96 | 139.39 |
| DZB-1CH-12V-80mA | 1.150 | 7.400 | 27.000 | 32.000 | 5.61 | 22.47 | 44.94 | 73.74 |
| DZB-1CH-12V-100mA | 1.150 | 7.400 | 27.000 | 32.000 | 3.16 | 12.64 | 25.28 | 41.47 |
| DZB-1CH-12V-125mA | 1.150 | 7.400 | 27.000 | 32.000 | 2.19 | 8.77 | 17.55 | 28.80 |
| DZB-1CH-12V-160mA | 1.150 | 7.400 | 27.000 | 32.000 | 1.33 | 5.34 | 10.68 | 17.52 |
| DZB-1CH-18V-50mA | 0.262 | 1.600 | 6.390 | 9.070 | 12.63 | 50.55 | 101.10 | 165.88 |
| DZB-1CH-18V-80mA | 0.262 | 1.600 | 6.390 | 9.070 | 5.61 | 22.47 | 44.94 | 73.74 |
| DZB-1CH-18V-100mA | 0.262 | 1.600 | 6.390 | 9.070 | 3.23 | 12.92 | 25.84 | 42.40 |
| DZB-1CH-18V-125mA | 0.262 | 1.600 | 6.390 | 9.070 | 2.19 | 8.77 | 17.55 | 28.80 |
| DZB-1CH-18V-160mA | 0.262 | 1.600 | 6.390 | 9.070 | 1.50 | 6.00 | 12.00 | 19.68 |
| DZB-1CH-24V-50mA | 0.107 | 0.820 | 2.900 | 4.800 | 12.12 | 48.48 | 96.97 | 159.09 |

Certificate: ExVeritas 20ATEX0665X

Issue 2

This certificate may only be reproduced in its entirety and without any change, schedule included.

For help or assistance relating to this certificate, contact info@exveritas.com.

ExVeritas ApS, Severinsmindevej 6, 4420 Regstrup, Denmark.

ExVeritas® is a registered trademark, unauthorised use will lead to prosecution.

Schedule

| Barrier Type | Co (µF) IIC | Co (µF) IIB | Co (µF) IIA | Co (µF) I | Lo (mH) IIC | Lo (mH) IIB | Lo (mH) IIA | Lo (mH) I |
|-------------------|----------------|----------------|----------------|--------------|----------------|----------------|----------------|--------------|
| DZB-1CH-24V-80mA | 0.107 | 0.820 | 2.900 | 4.800 | 7.11 | 28.44 | 56.88 | 93.33 |
| DZB-1CH-24V-100mA | 0.107 | 0.820 | 2.900 | 4.800 | 3.16 | 12.64 | 25.28 | 41.47 |
| DZB-1CH-24V-125mA | 0.101 | 0.780 | 2.670 | 4.570 | 2.53 | 10.13 | 20.27 | 33.25 |
| DZB-1CH-24V-160mA | (*) | 0.780 | 2.670 | 4.570 | (*) | 5.63 | 11.26 | 18.48 |
| DZB-1CH-28V-50mA | 0.071 | 0.587 | 1.910 | 3.270 | 12.63 | 50.55 | 101.10 | 165.88 |
| DZB-1CH-28V-80mA | 0.071 | 0.587 | 1.910 | 3.270 | 5.22 | 20.89 | 41.79 | 68.56 |
| DZB-1CH-28V-100mA | (*) | 0.497 | 1.620 | 2.810 | (*) | 12.64 | 25.28 | 41.47 |
| DZB-1CH-28V-125mA | (*) | 0.497 | 1.620 | 2.810 | (*) | 6.79 | 13.59 | 22.30 |
| DZB-1CH-36V-50mA | 0.037 | 0.339 | 1.070 | 1.930 | 10.62 | 42.48 | 84.96 | 139.39 |
| DZB-1CH-36V-80mA | (*) | 0.339 | 1.070 | 1.930 | (*) | 22.47 | 44.94 | 73.74 |
| DZB-1CH-36V-100mA | (*) | 0.339 | 1.070 | 1.930 | (*) | 12.64 | 25.28 | 41.47 |
| DZB-2CH-6V-50mA | 31.000 | 720.000 | 1000.000 | 1000.000 | 2.19 | 8.77 | 17.55 | 28.80 |
| DZB-2CH-6V-80mA | 31.000 | 720.000 | 1000.000 | 1000.000 | 1.23 | 4.93 | 9.87 | 16.20 |
| DZB-2CH-6V-100mA | 31.000 | 720.000 | 1000.000 | 1000.000 | 0.79 | 3.16 | 6.32 | 10.37 |
| DZB-2CH-6V-125mA | 31.000 | 720.000 | 1000.000 | 1000.000 | 0.50 | 2.02 | 4.04 | 6.63 |
| DZB-2CH-6V-160mA | 31.000 | 720.000 | 1000.000 | 1000.000 | 0.35 | 1.40 | 2.80 | 4.60 |
| DZB-2CH-10V-50mA | 2.410 | 16.800 | 75.000 | 95.000 | 3.16 | 12.64 | 25.28 | 41.47 |
| DZB-2CH-10V-80mA | 2.410 | 16.800 | 75.000 | 95.000 | 1.21 | 4.85 | 9.71 | 15.94 |
| DZB-2CH-10V-100mA | 2.410 | 16.800 | 75.000 | 95.000 | 0.82 | 3.28 | 6.57 | 10.78 |
| DZB-2CH-10V-125mA | 2.410 | 16.800 | 75.000 | 95.000 | 0.48 | 1.92 | 3.84 | 6.30 |
| DZB-2CH-10V-160mA | 2.140 | 15.000 | 66.000 | 80.000 | 0.33 | 1.32 | 2.64 | 4.33 |
| DZB-2CH-12V-50mA | 1.150 | 7.400 | 27.000 | 32.000 | 2.65 | 10.62 | 21.24 | 34.85 |
| DZB-2CH-12V-80mA | 1.150 | 7.400 | 27.000 | 32.000 | 1.47 | 5.90 | 11.80 | 19.36 |
| DZB-2CH-12V-100mA | 1.150 | 7.400 | 27.000 | 32.000 | 0.84 | 3.37 | 6.75 | 11.07 |
| DZB-2CH-12V-125mA | 1.150 | 7.400 | 27.000 | 32.000 | 0.57 | 2.28 | 4.56 | 7.49 |
| DZB-2CH-18V-50mA | 0.262 | 1.600 | 6.390 | 9.070 | 3.16 | 12.64 | 25.28 | 41.47 |
| DZB-2CH-18V-80mA | 0.262 | 1.600 | 6.390 | 9.070 | 1.40 | 5.61 | 11.23 | 18.43 |
| DZB-2CH-18V-100mA | 0.262 | 1.600 | 6.390 | 9.070 | 0.80 | 3.23 | 6.46 | 10.60 |
| DZB-2CH-24V-50mA | 0.107 | 0.820 | 2.900 | 4.800 | 3.16 | 12.64 | 25.28 | 41.47 |
| DZB-2CH-28V-50mA | (*) | 0.587 | 1.910 | 3.270 | (*) | 11.75 | 23.51 | 38.57 |
| DZB-2CH-36V-50mA | (*) | 0.339 | 1.070 | 1.930 | (*) | 10.62 | 21.24 | 34.85 |
| DZB-3CH-6V-50mA | 31.000 | 720.000 | 1000.000 | 1000.000 | 0.97 | 3.90 | 7.80 | 12.80 |
| DZB-3CH-6V-80mA | 31.000 | 720.000 | 1000.000 | 1000.000 | 0.54 | 2.19 | 4.38 | 7.20 |
| DZB-3CH-6V-100mA | 31.000 | 720.000 | 1000.000 | 1000.000 | 0.35 | 1.40 | 2.80 | 4.60 |
| DZB-3CH-6V-125mA | 31.000 | 720.000 | 1000.000 | 1000.000 | 0.22 | 0.89 | 1.79 | 2.95 |
| DZB-3CH-6V-160mA | 31.000 | 720.000 | 1000.000 | 1000.000 | 0.15 | 0.62 | 1.24 | 2.04 |
| DZB-3CH-10V-50mA | 2.410 | 16.800 | 75.000 | 95.000 | 1.40 | 5.61 | 11.23 | 18.43 |
| DZB-3CH-10V-80mA | 2.410 | 16.800 | 75.000 | 95.000 | 0.54 | 2.16 | 4.32 | 7.08 |
| DZB-3CH-10V-100mA | 2.410 | 16.800 | 75.000 | 95.000 | 0.36 | 1.46 | 2.92 | 4.79 |
| DZB-3CH-10V-125mA | 2.410 | 16.800 | 75.000 | 95.000 | 0.21 | 0.85 | 1.70 | 2.80 |
| DZB-3CH-10V-160mA | 2.140 | 15.000 | 66.000 | 80.000 | 0.14 | 0.58 | 1.17 | 1.92 |
| DZB-3CH-12V-50mA | 1.150 | 7.400 | 27.000 | 32.000 | 1.18 | 4.72 | 9.44 | 15.49 |
| DZB-3CH-12V-80mA | 1.150 | 7.400 | 27.000 | 32.000 | 0.65 | 2.62 | 5.24 | 8.60 |
| DZB-3CH-12V-100mA | 1.150 | 7.400 | 27.000 | 32.000 | 0.37 | 1.50 | 3.00 | 4.92 |
| DZB-3CH-12V-125mA | 1.150 | 7.400 | 27.000 | 32.000 | 0.25 | 1.01 | 2.02 | 3.33 |
| DZB-3CH-18V-50mA | 0.262 | 1.600 | 6.390 | 9.070 | 1.40 | 5.61 | 11.23 | 18.43 |
| DZB-3CH-18V-80mA | 0.262 | 1.600 | 6.390 | 9.070 | 0.62 | 2.49 | 4.99 | 8.19 |
| DZB-3CH-18V-100mA | 0.262 | 1.600 | 6.390 | 9.070 | 0.35 | 1.43 | 2.87 | 4.71 |
| DZB-3CH-24V-50mA | (*) | 0.820 | 2.900 | 4.800 | (*) | 5.61 | 11.23 | 18.43 |

Certificate: ExVeritas 20ATEX0665X

Issue 2

This certificate may only be reproduced in its entirety and without any change, schedule included.

 For help or assistance relating to this certificate, contact info@exveritas.com.

ExVeritas ApS, Severinsmindevej 6, 4420 Regstrup, Denmark.

ExVeritas® is a registered trademark, unauthorised use will lead to prosecution.

Schedule

| Barrier Type | Co (μF) IIC | Co (μF) IIB | Co (μF) IIA | Co (μF) I | Lo (mH) IIC | Lo (mH) IIB | Lo (mH) IIA | Lo (mH) I |
|------------------|----------------|----------------|----------------|--------------|----------------|----------------|----------------|--------------|
| DZB-3CH-28V-50mA | (*) | 0.587 | 1.910 | 3.270 | (*) | 5.22 | 10.44 | 17.14 |
| DZB-3CH-36V-50mA | (**) | (**) | 1.070 | 1.930 | (**) | (**) | 9.44 | 15.49 |

Mixed variants (different currents and potentials per channel)

| Barrier Type | Uo (V) | Io (mA) | Po (mW) | Lo/Ro (mH/Ω) IIC | Lo/Ro (mH/Ω) IIB | Lo/Ro (mH/Ω) IIA | Lo/Ro (mH/Ω) I |
|--------------------|-----------|------------|------------|------------------------|------------------------|------------------------|----------------------|
| DZB-2CHM-24/5-4/20 | 25.2 | 151.19 | 952.5 | 0.018 | 0.071 | 0.142 | 0.233 |
| DZB-2CHM-24/5 | 25.2 | 108.32 | 682.4 | 0.048 | 0.193 | 0.387 | 0.635 |
| DZB-2CHM-24/10 | 25.2 | 110.49 | 696.03 | 0.048 | 0.193 | 0.387 | 0.635 |

| Barrier Type | Co (μF) IIC | Co (μF) IIB | Co (μF) IIA | Co (μF) I | Lo (mH) IIC | Lo (mH) IIB | Lo (mH) IIA | Lo (mH) I |
|--------------------|----------------|----------------|----------------|--------------|----------------|----------------|----------------|--------------|
| DZB-2CHM-24/5-4/20 | 0.107 | 0.820 | 2.900 | 4.800 | 1.55 | 6.22 | 12.44 | 20.41 |
| DZB-2CHM-24/5 | 0.107 | 0.820 | 2.900 | 4.800 | 3.03 | 12.12 | 24.24 | 39.77 |
| DZB-2CHM-24/10 | 0.107 | 0.820 | 2.900 | 4.800 | 2.91 | 11.65 | 23.3 | 38.23 |

| Barrier Type | Uo (V) | Io (mA) | Po (mW) | Lo/Ro (mH/Ω) IIC | Lo/Ro (mH/Ω) IIB | Lo/Ro (mH/Ω) IIA | Lo/Ro (mH/Ω) I |
|-------------------|-----------|------------|------------|------------------------|------------------------|------------------------|----------------------|
| DZB-3CHM-24/5/5 | 25.2 | 153.45 | 966.74 | 0.017 | 0.069 | 0.137 | 0.225 |
| DZB-3CHM-24/10/10 | 25.2 | 88.39 | 556.82 | 0.056 | 0.224 | 0.448 | 0.735 |

| Barrier Type | Co (μF) IIC | Co (μF) IIB | Co (μF) IIA | Co (μF) I | Lo (mH) IIC | Lo (mH) IIB | Lo (mH) IIA | Lo (mH) I |
|-------------------|----------------|----------------|----------------|--------------|----------------|----------------|----------------|--------------|
| DZB-3CHM-24/5/5 | 0.107 | 0.820 | 2.900 | 4.800 | 1.5 | 6.03 | 12.07 | 19.81 |
| DZB-3CHM-24/10/10 | 0.107 | 0.820 | 2.900 | 4.800 | 4.55 | 18.2 | 36.41 | 59.73 |

14 Descriptive Documents

14.1 Associated Report and Certificate History:

| Report | Date | Issue | Comment |
|-----------|------------|-------|--|
| R2595/A/1 | 27/04/2021 | 0 | Initial issue of the Prime Certificate |
| R4537/A/1 | 21/04/2023 | 1 | Updated to include new enclosure material |
| R5075/A/1 | 05/02/2024 | 2 | Further update to include new enclosure material |

14.2 Compliance Drawings:

| Technical Documents | | | |
|---|------------|----------|------------|
| Title | Drawing | Revision | Date |
| Electronic schematic | LP700494 | H1 | 22/02/2021 |
| Printed circuit board artwork (Gerbers) | LP700494L | H1 | 14/08/2020 |
| Bill of materials | BOM700494 | 1 | 24/02/2021 |
| General assembly drawings * | D600806_1 | 5 | 01/11/2023 |
| General assembly drawings * | D600806_2 | 5 | 01/11/2023 |
| General assembly drawings * | D600806_3 | 5 | 01/11/2023 |
| Instruction manual | DZB Manual | 1 | 09/04/2021 |
| DZB Control drawing, 1 channel 6 V, 50 mA to 160 mA versions | D600807 | 1 | 12/02/2020 |
| DZB Control drawing, 1 channel 10 V, 50 mA to 160 mA versions | D600808 | 1 | 12/02/2020 |

Certificate: ExVeritas 20ATEX0665X

Issue 2

This certificate may only be reproduced in its entirety and without any change, schedule included.

For help or assistance relating to this certificate, contact info@exveritas.com.

ExVeritas ApS, Severinsmindevej 6, 4420 Regstrup, Denmark.

ExVeritas® is a registered trademark, unauthorised use will lead to prosecution.

Schedule

| Technical Documents | | | |
|---|---------|----------|------------|
| Title | Drawing | Revision | Date |
| DZB Control drawing, 1 channel 12 V, 50 mA to 160 mA versions | D600809 | 1 | 12/02/2020 |
| DZB Control drawing, 1 channel 18 V, 50 mA to 160 mA versions | D600810 | 1 | 12/02/2020 |
| DZB Control drawing, 1 channel 24 V, 50 mA to 125 mA versions | D600811 | 1 | 12/02/2020 |
| DZB Control drawing, 1 channel 24 V, 160 mA only | D600812 | 1 | 12/02/2020 |
| DZB Control drawing, 1 channel 28 V, 50 mA & 80 mA versions | D600813 | 1 | 12/02/2020 |
| DZB Control drawing, 1 channel 28 V, 100mA & 125 mA versions | D600814 | 1 | 12/02/2020 |
| DZB Control drawing, 1 channel 36 V, 50 mA version only | D600815 | 1 | 12/02/2020 |
| DZB Control drawing, 1 channel 36 V, 80 mA & 100 mA versions | D600816 | 1 | 12/02/2020 |
| DZB Control drawing, 2 channel 6 V, 50 mA to 160 mA versions | D600817 | 1 | 12/02/2020 |
| DZB Control drawing, 2 channel 10 V, 50 mA to 160 mA versions | D600818 | 1 | 12/02/2020 |
| DZB Control drawing, 2 channel 12 V, 50 mA to 125 mA versions | D600819 | 1 | 12/02/2020 |
| DZB Control drawing, 2 channel, 18 V 50 mA, 80 mA & 100 mA versions | D600820 | 1 | 12/02/2020 |
| DZB Control drawing, 2 channel, 24 V 50 mA version only | D600821 | 1 | 12/02/2020 |
| DZB Control drawing, 2 channel, 28 V 50 mA version only | D600822 | 1 | 12/02/2020 |
| DZB Control drawing, 2 channel 36 V 50 mA version only | D600823 | 1 | 12/02/2020 |
| DZB Control drawing, mixed version 24V 50 mA and 5 V 40 mA | D600825 | 1 | 12/02/2020 |
| DZB Control drawing, mixed version 24 V 50 mA and 40 mA | D600826 | 1 | 12/02/2020 |
| DZB Control drawing, 2 channel mixed version 24 V 50 mA and 10 V 40 mA | D600827 | 1 | 12/02/2020 |
| DZB drawing, 3 channel mixed version 24V / 5V / 5V, 50 mA, 40 mA, 40 mA | D600828 | 1 | 12/02/2020 |
| DZB drawing, 3 channel mixed version 24 V / 10V / 10V, 50 mA, 40 mA, 40mA | D600829 | 1 | 12/02/2020 |
| DZB drawing, 3 channel 6 V version 50 mA, 80 mA, 100 mA, 125 mA, 160 mA | D600833 | 1 | 12/02/2020 |
| DZB drawing, 3 channel 10 V version 50 mA, 80 mA, 100 mA, 125 mA, 160 mA | D600834 | 1 | 12/02/2020 |
| DZB drawing, 3 channel 12 V version 50 mA, 80 mA, 100 mA, 125 mA | D600835 | 1 | 12/02/2020 |
| DZB Control drawing, 3 channel 18 V version 50 mA, 80 mA, 100 mA | D600836 | 1 | 12/02/2020 |
| DZB Control drawing, 3 channel 24 V 50 mA version only | D600837 | 1 | 12/02/2020 |
| DZB Control drawing, 3 channel 28 V 50 mA version only | D600838 | 1 | 12/02/2020 |
| DZB Control drawing, 3 channel 36 V 50 mA version only | D600839 | 1 | 12/02/2020 |
| 242 Series - Suitability for Encapsulation or Conformal Coating rev 3 | N/A | 3 | 20/12/2017 |

* indicates an update in this certificate issue.

15 Conditions of Certification

15.1 Special Conditions for Safe Use

1. The intrinsically safe circuits are not segregated from the ground circuit, all the limiting circuits are based on Zener barriers and therefore there is no insulation between the intrinsically safe circuits and the grounding circuit. Therefore, the barriers does not comply with the dielectric strength requirements from clause 6.3.13 of IEC 60079-11.
2. The barriers must be installed an enclosure meeting the requirements of IP20 in accordance with IEC 60529 or greater according to the intended use and environmental conditions.

15.2 Conditions for Use (Routine tests)

IEC 60079-11:2011 Cl, 11.1.1. – Routine tests for diode safety barriers (completed barriers)

16 Essential Health and Safety Requirements

Essential Health and Safety Requirements are addressed by the standards listed in section 9 and where required the report listed in section 14.1. The manufacturer shall inform the Notified Body of any modifications to the design of the product described by this schedule.

Certificate: ExVeritas 20ATEX0665X

Issue 2

This certificate may only be reproduced in its entirety and without any change, schedule included.

For help or assistance relating to this certificate, contact info@exveritas.com.

ExVeritas ApS, Severinsmindevej 6, 4420 Regstrup, Denmark.

ExVeritas® is a registered trademark, unauthorised use will lead to prosecution.



IECEX Certificate of Conformity

INTERNATIONAL ELECTROTECHNICAL COMMISSION IEC Certification System for Explosive Atmospheres

for rules and details of the IECEx Scheme visit www.iecex.com

| | | | |
|---------------------|---|-------------|--|
| Certificate No.: | IECEX EXV 20.0022X | Page 1 of 5 | <u>Certificate history:</u> |
| Status: | Current | Issue No: 2 | Issue 1 (2023-05-26) Issue 0 (2021-04-27) |
| Date of Issue: | 2024-03-06 | | |
| Applicant: | Deeter Electronics Limited Deeter House Valley Road Hughenden Valley High Wycombe Bucks HP14 4LW United Kingdom | | |
| Equipment: | Deeter Zener Barrier DZB-□CH□-□□V-□□mA | | |
| Optional accessory: | | | |
| Type of Protection: | Intrinsically safe | | |
| Marking: | Marking depends on barrier type, please see annex for disambiguation. | | |

Approved for issue on behalf of the IECEx
Certification Body:

Sean Clarke CEng MSc FIET

Position:

Certification Manager

Signature:
(for printed version)

Date:
(for printed version)

1. This certificate and schedule may only be reproduced in full.
2. This certificate is not transferable and remains the property of the issuing body.
3. The Status and authenticity of this certificate may be verified by visiting www.iecex.com or use of this QR Code.



Certificate issued by:

ExVeritas Limited
Units 16-18 Abenbury Way
Wrexham Ind. Est.
Wrexham LL 139UZ
United Kingdom





IECEX Certificate of Conformity

Certificate No.: **IECEX EXV 20.0022X**

Page 2 of 5

Date of issue: 2024-03-06

Issue No: 2

Manufacturer: **Deeter Electronics Limited**
Deeter House
Valley Road
Hughenden Valley
High Wycombe
Bucks HP14 4LW
United Kingdom

Manufacturing
locations:

This certificate is issued as verification that a sample(s), representative of production, was assessed and tested and found to comply with the IEC Standard list below and that the manufacturer's quality system, relating to the Ex products covered by this certificate, was assessed and found to comply with the IECEX Quality system requirements. This certificate is granted subject to the conditions as set out in IECEX Scheme Rules, IECEX 02 and Operational Documents as amended

STANDARDS :

The equipment and any acceptable variations to it specified in the schedule of this certificate and the identified documents, was found to comply with the following standards

[IEC 60079-0:2017](#) Explosive atmospheres - Part 0: Equipment - General requirements
Edition:7.0

[IEC 60079-11:2011](#) Explosive atmospheres - Part 11: Equipment protection by intrinsic safety "I"
Edition:6.0

This Certificate **does not** indicate compliance with safety and performance requirements other than those expressly included in the Standards listed above.

TEST & ASSESSMENT REPORTS:

A sample(s) of the equipment listed has successfully met the examination and test requirements as recorded in:

Test Reports:

[GB/EXV/ExTR20.0038/00](#)

[GB/EXV/ExTR23.0046/00](#)

[GB/EXV/ExTR24.0015/00](#)

Quality Assessment Reports:

[GB/SIR/QAR12.0004/08](#)

[GB/SIR/QAR12.0004/10](#)



IECEx Certificate of Conformity

Certificate No.: **IECEx EXV 20.0022X**

Page 3 of 5

Date of issue: 2024-03-06

Issue No: 2

EQUIPMENT:

Equipment and systems covered by this Certificate are as follows:

The DZB Zener Barrier is designed for fixed installation into a DIN Rail with a rating of $U_m = 250$ V.

The barrier has one, two, or three channels which have identical electrical parameters for Current, Voltage, and Power on each channel. There are also a select few variants which have 'mixed' channels where each of the two or three channels may have a differing electrical parameters to the alternate channels. The product types are differentiated using the following product code:

Product name: DZB-□CH□-□□V-□□mA

The product name uses the character '□' to reveal the barrier characteristics following from left to right:

□CH□ - Number of channels (Prefix is either 1, 2 or 3 and/or with the postfix 'M' indicating mixed voltages/currents on individual channels)

□□V - Potential difference (volts) per individual channel (DC) [except for mixed voltage variants]

□□mA - Current in milliamperes per individual channel [except for mixed voltage variants]

Given that each barrier has up to 3 channels, and also given the electrical characteristics the entity parameters in each case is calculated considering the channels combined. When using and installing the device the parameters must be considered in consonance with IEC 60079-11 Cl, 10.1.5.2. where:

1. The external circuit contains no combined lumped inductance 'Li' and capacitance 'Ci' greater than 1% of the values in the table below or;
2. The inductance and capacitance are distributed as in a cable or;
3. The external circuit contains either only lumped inductance or lumped capacitance in combination with a cable

In all other situations e.g. the external circuit combined lumped inductance and lumped capacitance, up to 50% of each of the L_o and C_o values is allowed.

Excluding the models listed below, all the models are marked as:

I (M1) [Ex ia Ma] I

II (1)G [Ex ia Ga] IIC

II (1)D [Ex ia Da] IIIC

The models DZB-1CH-24V-160mA, DZB-1CH-28V-100mA, DZB-1CH-28V-125mA, DZB-1CH-36V-80mA,

DZB-1CH-36V-100mA, DZB-2CH-28V-50mA, DZB-2CH-36V-50mA, DZB-3CH-24V-50mA and DZB-3CH-28V-50mA are marked as:

[Ex ia Ma] I

[Ex ia Ga] IIB

[Ex ia Da] IIIC

The model DZB-3CH-36V-50mA is marked as:

[Ex ia Ma] I

[Ex ia Ga] IIA

1, 2, and 3 channel variants (same currents and voltages per channel), entity parameters calculated with the channels associated in parallel: See appendix for Entity Parameters.

SPECIFIC CONDITIONS OF USE: YES as shown below:

1. The intrinsically safe circuits are not segregated from the ground circuit, all the limiting circuits are based on Zener barriers and therefore there is no insulation between the intrinsically safe circuits and the grounding circuit. Therefore, the barriers does not comply with the dielectric strength requirements from clause 6.3.13 of IEC 60079-11.
2. The barriers must be installed an enclosure meeting the requirements of IP20 in accordance with IEC 60529 or greater according to the intended use and environmental conditions.



IECEX Certificate of Conformity

Certificate No.: **IECEX EXV 20.0022X**

Page 4 of 5

Date of issue: 2024-03-06

Issue No: 2

DETAILS OF CERTIFICATE CHANGES (for issues 1 and above)

This revision has been necessary to allow the inclusion of a new enclosure material type.



IECEX Certificate of Conformity

Certificate No.: **IECEX EXV 20.0022X**

Page 5 of 5

Date of issue: 2024-03-06

Issue No: 2

Additional information:
See Annex for Routine tests

Annex:

[IECEX Certificate annex.pdf](#)

Description continued

The DZB (Deeter Zener Barrier) is designed for fixed installation into a DIN Rail with a rating of $U_m = 250$ V. The barrier has one, two, or three channels which have identical electrical parameters for Current, Voltage, and Power on each channel. There are also a select few variants which have 'mixed' channels where each of the two or three channels may have a differing electrical parameters to the alternate channels. The product types are differentiated using the following product code:

Product name: DZB – □ CH □ – □□V – □□ mA

The product name uses the character '□' to reveal the barrier characteristics following from left to right:



- CH □ Number of channels (Prefix is either 1, 2 or 3 and/or with the postfix 'M' indicating mixed voltages/currents on individual channels)
- Vdc Potential difference (Volts) per individual channel
- mA Current in milliamperes per individual channel

Given that each barrier has up to 3 channels, and also given the electrical characteristics the entity parameters in each case is calculated considering the channels combined. When using and installing the device the parameters must be considered in consonance with IEC 60079-11 Cl, 10.1.5.2. where:



1. The external circuit contains no combined lumped inductance 'Li' and capacitance 'Ci' greater than 1% of the values in the table below or;
2. The inductance and capacitance are distributed as in a cable or;
3. The external circuit contains either only lumped inductance or lumped capacitance in combination with a cable.

In all other situations e.g. the external circuit combined lumped inductance and lumped capacitance, up to 50% of each of the L_o and C_o values is allowed.



Excluding the models listed below, all the models are marked as:

-  I (M1) [Ex ia Ma] I
-  II (1)G [Ex ia Ga] IIC
-  II (1)D [Ex ia Da] IIIC

The models DZB-1CH-24V-160mA, DZB-1CH-28V-100mA, DZB-1CH-28V-125mA, DZB-1CH-36V-80mA, DZB-1CH-36V-100mA, DZB-2CH-28V-50mA, DZB-2CH-36V-50mA, DZB-3CH-24V-50mA and DZB-3CH-28V-50mA are marked as:

-  I (M1) [Ex ia Ma] I
-  II (1)G [Ex ia Ga] IIB
-  II (1)D [Ex ia Da] IIIC

The model DZB-3CH-36V-50mA is marked as:

-  I (M1) [Ex ia Ma] I
-  II (1)G [Ex ia Ga] IIA

1, 2, and 3 channel variants (same currents and voltages per channel), entity parameters calculated with the channels associated in parallel:

Table key: * = Not suitable for IIC, ** = Not suitable for IIB

| Barrier Type | U _o (V) | I _o (mA) | P _o (mW) | Lo/Ro (mH/Ω) IIC | Lo/Ro (mH/Ω) IIB | Lo/Ro (mH/Ω) IIA | Lo/Ro (mH/Ω) I |
|-------------------|-----------------------|------------------------|------------------------|------------------------|------------------------|------------------------|----------------------|
| DZB-1CH-6V-50mA | 6.3 | 63.64 | 100.24 | 0.35 | 1.41 | 2.83 | 4.65 |
| DZB-1CH-6V-80mA | 6.3 | 84.85 | 133.64 | 0.26 | 1.06 | 2.12 | 3.49 |
| DZB-1CH-6V-100mA | 6.3 | 102.64 | 161.66 | 0.21 | 0.87 | 1.75 | 2.88 |
| DZB-1CH-6V-125mA | 6.3 | 124.78 | 196.53 | 0.18 | 0.72 | 1.44 | 2.37 |
| DZB-1CH-6V-160mA | 6.3 | 163.18 | 257.01 | 0.13 | 0.55 | 1.1 | 1.81 |
| DZB-1CH-10V-50mA | 10.5 | 53.04 | 139.23 | 0.25 | 1.02 | 2.04 | 3.35 |
| DZB-1CH-10V-80mA | 10.5 | 85.54 | 224.55 | 0.15 | 0.63 | 1.26 | 2.07 |
| DZB-1CH-10V-100mA | 10.5 | 106.07 | 278.44 | 0.12 | 0.51 | 1.02 | 1.67 |
| DZB-1CH-10V-125mA | 10.5 | 129.35 | 339.55 | 0.1 | 0.41 | 0.83 | 1.37 |
| DZB-1CH-10V-160mA | 10.72 | 164.07 | 439.71 | 0.08 | 0.32 | 0.64 | 1.06 |
| DZB-1CH-12V-50mA | 12.6 | 57.86 | 182.26 | 0.19 | 0.78 | 1.56 | 2.56 |
| DZB-1CH-12V-80mA | 12.6 | 79.55 | 250.59 | 0.14 | 0.56 | 1.13 | 1.86 |
| DZB-1CH-12V-100mA | 12.6 | 106.07 | 334.13 | 0.1 | 0.42 | 0.85 | 1.39 |
| DZB-1CH-12V-125mA | 12.6 | 127.28 | 400.94 | 0.08 | 0.35 | 0.7 | 1.16 |
| DZB-1CH-12V-160mA | 12.6 | 163.18 | 514.02 | 0.06 | 0.27 | 0.55 | 0.9 |
| DZB-1CH-18V-50mA | 18.9 | 53.04 | 250.62 | 0.14 | 0.56 | 1.13 | 1.86 |
| DZB-1CH-18V-80mA | 18.9 | 79.55 | 375.88 | 0.09 | 0.37 | 0.75 | 1.24 |
| DZB-1CH-18V-100mA | 18.9 | 104.9 | 495.66 | 0.07 | 0.28 | 0.57 | 0.94 |
| DZB-1CH-18V-125mA | 18.9 | 127.28 | 601.4 | 0.05 | 0.23 | 0.47 | 0.77 |
| DZB-1CH-18V-160mA | 18.9 | 153.96 | 727.47 | 0.04 | 0.19 | 0.39 | 0.64 |
| DZB-1CH-24V-50mA | 25.2 | 54.16 | 341.21 | 0.1 | 0.41 | 0.83 | 1.36 |
| DZB-1CH-24V-80mA | 25.2 | 70.71 | 445.48 | 0.07 | 0.31 | 0.63 | 1.04 |
| DZB-1CH-24V-100mA | 25.2 | 106.07 | 668.25 | 0.05 | 0.21 | 0.42 | 0.69 |
| DZB-1CH-24V-125mA | 25.8 | 118.46 | 764.07 | 0.04 | 0.18 | 0.37 | 0.61 |
| DZB-1CH-24V-160mA | 25.8 | 158.91 | 1024.97 | (*) | 0.13 | 0.27 | 0.45 |
| DZB-1CH-28V-50mA | 29.4 | 53.04 | 389.85 | 0.09 | 0.36 | 0.72 | 1.19 |
| DZB-1CH-28V-80mA | 29.4 | 82.5 | 606.38 | 0.05 | 0.23 | 0.46 | 0.76 |
| DZB-1CH-28V-100mA | 31.5 | 106.07 | 835.31 | (*) | 0.17 | 0.34 | 0.55 |
| DZB-1CH-28V-125mA | 31.5 | 144.63 | 1138.97 | (*) | 0.12 | 0.24 | 0.4 |
| DZB-1CH-36V-50mA | 37.8 | 57.86 | 546.78 | 0.06 | 0.26 | 0.52 | 0.85 |
| DZB-1CH-36V-80mA | 37.8 | 79.55 | 751.75 | (*) | 0.18 | 0.37 | 0.62 |
| DZB-1CH-36V-100mA | 37.8 | 106.07 | 1002.37 | (*) | 0.14 | 0.28 | 0.46 |
| DZB-2CH-6V-50mA | 6.3 | 127.28 | 200.47 | 0.35 | 1.41 | 2.83 | 4.65 |
| DZB-2CH-6V-80mA | 6.3 | 169.7 | 267.28 | 0.26 | 1.06 | 2.12 | 3.49 |
| DZB-2CH-6V-100mA | 6.3 | 212.13 | 334.11 | 0.21 | 0.85 | 1.7 | 2.79 |
| DZB-2CH-6V-125mA | 6.3 | 265.16 | 417.63 | 0.17 | 0.68 | 1.36 | 2.23 |
| DZB-2CH-6V-160mA | 6.3 | 318.19 | 501.15 | 0.14 | 0.56 | 1.13 | 1.86 |
| DZB-2CH-10V-50mA | 10.5 | 106.07 | 278.44 | 0.25 | 1.02 | 2.04 | 3.35 |
| DZB-2CH-10V-80mA | 10.5 | 171.07 | 449.06 | 0.15 | 0.63 | 1.26 | 2.07 |
| DZB-2CH-10V-100mA | 10.5 | 207.97 | 545.93 | 0.13 | 0.52 | 1.04 | 1.7 |
| DZB-2CH-10V-125mA | 10.5 | 271.96 | 713.9 | 0.09 | 0.39 | 0.79 | 1.3 |
| DZB-2CH-10V-160mA | 10.72 | 328.13 | 879.39 | 0.08 | 0.32 | 0.64 | 1.06 |
| DZB-2CH-12V-50mA | 12.6 | 115.71 | 364.49 | 0.19 | 0.78 | 1.56 | 2.56 |
| DZB-2CH-12V-80mA | 12.6 | 155.22 | 488.95 | 0.14 | 0.58 | 1.16 | 1.9 |
| DZB-2CH-12V-100mA | 12.6 | 205.28 | 646.64 | 0.1 | 0.43 | 0.87 | 1.44 |
| DZB-2CH-12V-125mA | 12.6 | 249.56 | 786.12 | 0.09 | 0.36 | 0.72 | 1.18 |
| DZB-2CH-18V-50mA | 18.9 | 106.07 | 501.19 | 0.14 | 0.56 | 1.13 | 1.86 |
| DZB-2CH-18V-80mA | 18.9 | 159.1 | 751.75 | 0.09 | 0.37 | 0.75 | 1.24 |
| DZB-2CH-18V-100mA | 18.9 | 209.8 | 991.31 | 0.07 | 0.28 | 0.57 | 0.94 |
| DZB-2CH-24V-50mA | 25.2 | 106.07 | 668.25 | 0.1 | 0.42 | 0.85 | 1.39 |
| DZB-2CH-28V-50mA | 29.4 | 109.99 | 808.43 | (*) | 0.35 | 0.7 | 1.15 |
| DZB-2CH-36V-50mA | 37.8 | 115.71 | 1093.46 | (*) | 0.26 | 0.52 | 0.85 |
| DZB-3CH-6V-50mA | 6.3 | 190.91 | 300.69 | 0.35 | 1.41 | 2.83 | 4.65 |
| DZB-3CH-6V-80mA | 6.3 | 254.55 | 400.92 | 0.26 | 1.06 | 2.12 | 3.49 |
| DZB-3CH-6V-100mA | 6.3 | 318.19 | 501.15 | 0.21 | 0.85 | 1.7 | 2.79 |
| DZB-3CH-6V-125mA | 6.3 | 397.73 | 626.43 | 0.17 | 0.68 | 1.36 | 2.23 |
| DZB-3CH-6V-160mA | 6.3 | 477.28 | 751.72 | 0.14 | 0.56 | 1.13 | 1.86 |
| DZB-3CH-10V-50mA | 10.5 | 159.1 | 417.64 | 0.25 | 1.02 | 2.04 | 3.35 |
| DZB-3CH-10V-80mA | 10.5 | 256.6 | 673.58 | 0.15 | 0.63 | 1.26 | 2.07 |
| DZB-3CH-10V-100mA | 10.5 | 311.95 | 818.87 | 0.13 | 0.52 | 1.04 | 1.7 |

| Barrier Type | U _o (V) | I _o (mA) | P _o (mW) | Lo/Ro (mH/Ω) IIC | Lo/Ro (mH/Ω) IIB | Lo/Ro (mH/Ω) IIA | Lo/Ro (mH/Ω) I |
|-------------------|-----------------------|------------------------|------------------------|------------------------|------------------------|------------------------|----------------------|
| DZB-3CH-10V-125mA | 10.5 | 407.93 | 1070.82 | 0.09 | 0.39 | 0.79 | 1.3 |
| DZB-3CH-10V-160mA | 10.72 | 492.2 | 1319.1 | 0.08 | 0.32 | 0.64 | 1.06 |
| DZB-3CH-12V-50mA | 12.6 | 173.56 | 546.72 | 0.19 | 0.78 | 1.56 | 2.56 |
| DZB-3CH-12V-80mA | 12.6 | 232.82 | 733.39 | 0.14 | 0.58 | 1.16 | 1.9 |
| DZB-3CH-12V-100mA | 12.6 | 307.92 | 969.95 | 0.1 | 0.43 | 0.87 | 1.44 |
| DZB-3CH-12V-125mA | 12.6 | 374.34 | 1179.18 | 0.09 | 0.36 | 0.72 | 1.18 |
| DZB-3CH-18V-50mA | 18.9 | 159.1 | 751.75 | 0.14 | 0.56 | 1.13 | 1.86 |
| DZB-3CH-18V-80mA | 18.9 | 238.64 | 1127.58 | 0.09 | 0.37 | 0.75 | 1.24 |
| DZB-3CH-18V-100mA | 18.9 | 314.69 | 1486.92 | 0.07 | 0.28 | 0.57 | 0.94 |
| DZB-3CH-24V-50mA | 25.2 | 159.1 | 1002.33 | (*) | 0.42 | 0.85 | 1.39 |
| DZB-3CH-28V-50mA | 29.4 | 164.99 | 1212.68 | (*) | 0.35 | 0.7 | 1.15 |
| DZB-3CH-36V-50mA | 37.8 | 173.56 | 1640.15 | (**) | (**) | 0.52 | 0.85 |

| Barrier Type | Co (μF) IIC | Co (μF) IIB | Co (μF) IIA | Co (μF) I | Lo (mH) IIC | Lo (mH) IIB | Lo (mH) IIA | Lo (mH) I |
|-------------------|----------------|----------------|----------------|--------------|----------------|----------------|----------------|--------------|
| DZB-1CH-6V-50mA | 31.000 | 720.000 | 1000.000 | 1000.000 | 8.77 | 35.11 | 70.23 | 115.22 |
| DZB-1CH-6V-80mA | 31.000 | 720.000 | 1000.000 | 1000.000 | 4.93 | 19.75 | 39.50 | 64.81 |
| DZB-1CH-6V-100mA | 31.000 | 720.000 | 1000.000 | 1000.000 | 3.37 | 13.50 | 27.00 | 44.29 |
| DZB-1CH-6V-125mA | 31.000 | 720.000 | 1000.000 | 1000.000 | 2.28 | 9.13 | 18.26 | 29.97 |
| DZB-1CH-6V-160mA | 31.000 | 720.000 | 1000.000 | 1000.000 | 1.33 | 5.34 | 10.68 | 17.52 |
| DZB-1CH-10V-50mA | 2.410 | 16.800 | 75.000 | 95.000 | 12.63 | 50.55 | 101.10 | 165.88 |
| DZB-1CH-10V-80mA | 2.410 | 16.800 | 75.000 | 95.000 | 4.85 | 19.43 | 38.87 | 63.77 |
| DZB-1CH-10V-100mA | 2.410 | 16.800 | 75.000 | 95.000 | 3.16 | 12.64 | 25.28 | 41.47 |
| DZB-1CH-10V-125mA | 2.410 | 16.800 | 75.000 | 95.000 | 2.12 | 8.50 | 17.00 | 27.89 |
| DZB-1CH-10V-160mA | 2.140 | 15.000 | 66.000 | 80.000 | 1.32 | 5.28 | 10.56 | 17.33 |
| DZB-1CH-12V-50mA | 1.150 | 7.400 | 27.000 | 32.000 | 10.62 | 42.48 | 84.96 | 139.39 |
| DZB-1CH-12V-80mA | 1.150 | 7.400 | 27.000 | 32.000 | 5.61 | 22.47 | 44.94 | 73.74 |
| DZB-1CH-12V-100mA | 1.150 | 7.400 | 27.000 | 32.000 | 3.16 | 12.64 | 25.28 | 41.47 |
| DZB-1CH-12V-125mA | 1.150 | 7.400 | 27.000 | 32.000 | 2.19 | 8.77 | 17.55 | 28.80 |
| DZB-1CH-12V-160mA | 1.150 | 7.400 | 27.000 | 32.000 | 1.33 | 5.34 | 10.68 | 17.52 |
| DZB-1CH-18V-50mA | 0.262 | 1.600 | 6.390 | 9.070 | 12.63 | 50.55 | 101.10 | 165.88 |
| DZB-1CH-18V-80mA | 0.262 | 1.600 | 6.390 | 9.070 | 5.61 | 22.47 | 44.94 | 73.74 |
| DZB-1CH-18V-100mA | 0.262 | 1.600 | 6.390 | 9.070 | 3.23 | 12.92 | 25.84 | 42.40 |
| DZB-1CH-18V-125mA | 0.262 | 1.600 | 6.390 | 9.070 | 2.19 | 8.77 | 17.55 | 28.80 |
| DZB-1CH-18V-160mA | 0.262 | 1.600 | 6.390 | 9.070 | 1.50 | 6.00 | 12.00 | 19.68 |
| DZB-1CH-24V-50mA | 0.107 | 0.820 | 2.900 | 4.800 | 12.12 | 48.48 | 96.97 | 159.09 |
| DZB-1CH-24V-80mA | 0.107 | 0.820 | 2.900 | 4.800 | 7.11 | 28.44 | 56.88 | 93.33 |
| DZB-1CH-24V-100mA | 0.107 | 0.820 | 2.900 | 4.800 | 3.16 | 12.64 | 25.28 | 41.47 |
| DZB-1CH-24V-125mA | 0.101 | 0.780 | 2.670 | 4.570 | 2.53 | 10.13 | 20.27 | 33.25 |
| DZB-1CH-24V-160mA | (*) | 0.780 | 2.670 | 4.570 | (*) | 5.63 | 11.26 | 18.48 |
| DZB-1CH-28V-50mA | 0.071 | 0.587 | 1.910 | 3.270 | 12.63 | 50.55 | 101.10 | 165.88 |
| DZB-1CH-28V-80mA | 0.071 | 0.587 | 1.910 | 3.270 | 5.22 | 20.89 | 41.79 | 68.56 |
| DZB-1CH-28V-100mA | (*) | 0.497 | 1.620 | 2.810 | (*) | 12.64 | 25.28 | 41.47 |
| DZB-1CH-28V-125mA | (*) | 0.497 | 1.620 | 2.810 | (*) | 6.79 | 13.59 | 22.30 |
| DZB-1CH-36V-50mA | 0.037 | 0.339 | 1.070 | 1.930 | 10.62 | 42.48 | 84.96 | 139.39 |
| DZB-1CH-36V-80mA | (*) | 0.339 | 1.070 | 1.930 | (*) | 22.47 | 44.94 | 73.74 |
| DZB-1CH-36V-100mA | (*) | 0.339 | 1.070 | 1.930 | (*) | 12.64 | 25.28 | 41.47 |
| DZB-2CH-6V-50mA | 31.000 | 720.000 | 1000.000 | 1000.000 | 2.19 | 8.77 | 17.55 | 28.80 |
| DZB-2CH-6V-80mA | 31.000 | 720.000 | 1000.000 | 1000.000 | 1.23 | 4.93 | 9.87 | 16.20 |
| DZB-2CH-6V-100mA | 31.000 | 720.000 | 1000.000 | 1000.000 | 0.79 | 3.16 | 6.32 | 10.37 |
| DZB-2CH-6V-125mA | 31.000 | 720.000 | 1000.000 | 1000.000 | 0.50 | 2.02 | 4.04 | 6.63 |
| DZB-2CH-6V-160mA | 31.000 | 720.000 | 1000.000 | 1000.000 | 0.35 | 1.40 | 2.80 | 4.60 |
| DZB-2CH-10V-50mA | 2.410 | 16.800 | 75.000 | 95.000 | 3.16 | 12.64 | 25.28 | 41.47 |
| DZB-2CH-10V-80mA | 2.410 | 16.800 | 75.000 | 95.000 | 1.21 | 4.85 | 9.71 | 15.94 |
| DZB-2CH-10V-100mA | 2.410 | 16.800 | 75.000 | 95.000 | 0.82 | 3.28 | 6.57 | 10.78 |
| DZB-2CH-10V-125mA | 2.410 | 16.800 | 75.000 | 95.000 | 0.48 | 1.92 | 3.84 | 6.30 |
| DZB-2CH-10V-160mA | 2.140 | 15.000 | 66.000 | 80.000 | 0.33 | 1.32 | 2.64 | 4.33 |
| DZB-2CH-12V-50mA | 1.150 | 7.400 | 27.000 | 32.000 | 2.65 | 10.62 | 21.24 | 34.85 |
| DZB-2CH-12V-80mA | 1.150 | 7.400 | 27.000 | 32.000 | 1.47 | 5.90 | 11.80 | 19.36 |

| Barrier Type | Co (μF) IIC | Co (μF) IIB | Co (μF) IIA | Co (μF) I | Lo (mH) IIC | Lo (mH) IIB | Lo (mH) IIA | Lo (mH) I |
|-------------------|----------------|----------------|----------------|--------------|----------------|----------------|----------------|--------------|
| DZB-2CH-12V-100mA | 1.150 | 7.400 | 27.000 | 32.000 | 0.84 | 3.37 | 6.75 | 11.07 |
| DZB-2CH-12V-125mA | 1.150 | 7.400 | 27.000 | 32.000 | 0.57 | 2.28 | 4.56 | 7.49 |
| DZB-2CH-18V-50mA | 0.262 | 1.600 | 6.390 | 9.070 | 3.16 | 12.64 | 25.28 | 41.47 |
| DZB-2CH-18V-80mA | 0.262 | 1.600 | 6.390 | 9.070 | 1.40 | 5.61 | 11.23 | 18.43 |
| DZB-2CH-18V-100mA | 0.262 | 1.600 | 6.390 | 9.070 | 0.80 | 3.23 | 6.46 | 10.60 |
| DZB-2CH-24V-50mA | 0.107 | 0.820 | 2.900 | 4.800 | 3.16 | 12.64 | 25.28 | 41.47 |
| DZB-2CH-28V-50mA | (*) | 0.587 | 1.910 | 3.270 | (*) | 11.75 | 23.51 | 38.57 |
| DZB-2CH-36V-50mA | (*) | 0.339 | 1.070 | 1.930 | (*) | 10.62 | 21.24 | 34.85 |
| DZB-3CH-6V-50mA | 31.000 | 720.000 | 1000.000 | 1000.000 | 0.97 | 3.90 | 7.80 | 12.80 |
| DZB-3CH-6V-80mA | 31.000 | 720.000 | 1000.000 | 1000.000 | 0.54 | 2.19 | 4.38 | 7.20 |
| DZB-3CH-6V-100mA | 31.000 | 720.000 | 1000.000 | 1000.000 | 0.35 | 1.40 | 2.80 | 4.60 |
| DZB-3CH-6V-125mA | 31.000 | 720.000 | 1000.000 | 1000.000 | 0.22 | 0.89 | 1.79 | 2.95 |
| DZB-3CH-6V-160mA | 31.000 | 720.000 | 1000.000 | 1000.000 | 0.15 | 0.62 | 1.24 | 2.04 |
| DZB-3CH-10V-50mA | 2.410 | 16.800 | 75.000 | 95.000 | 1.40 | 5.61 | 11.23 | 18.43 |
| DZB-3CH-10V-80mA | 2.410 | 16.800 | 75.000 | 95.000 | 0.54 | 2.16 | 4.32 | 7.08 |
| DZB-3CH-10V-100mA | 2.410 | 16.800 | 75.000 | 95.000 | 0.36 | 1.46 | 2.92 | 4.79 |
| DZB-3CH-10V-125mA | 2.410 | 16.800 | 75.000 | 95.000 | 0.21 | 0.85 | 1.70 | 2.80 |
| DZB-3CH-10V-160mA | 2.140 | 15.000 | 66.000 | 80.000 | 0.14 | 0.58 | 1.17 | 1.92 |
| DZB-3CH-12V-50mA | 1.150 | 7.400 | 27.000 | 32.000 | 1.18 | 4.72 | 9.44 | 15.49 |
| DZB-3CH-12V-80mA | 1.150 | 7.400 | 27.000 | 32.000 | 0.65 | 2.62 | 5.24 | 8.60 |
| DZB-3CH-12V-100mA | 1.150 | 7.400 | 27.000 | 32.000 | 0.37 | 1.50 | 3.00 | 4.92 |
| DZB-3CH-12V-125mA | 1.150 | 7.400 | 27.000 | 32.000 | 0.25 | 1.01 | 2.02 | 3.33 |
| DZB-3CH-18V-50mA | 0.262 | 1.600 | 6.390 | 9.070 | 1.40 | 5.61 | 11.23 | 18.43 |
| DZB-3CH-18V-80mA | 0.262 | 1.600 | 6.390 | 9.070 | 0.62 | 2.49 | 4.99 | 8.19 |
| DZB-3CH-18V-100mA | 0.262 | 1.600 | 6.390 | 9.070 | 0.35 | 1.43 | 2.87 | 4.71 |
| DZB-3CH-24V-50mA | (*) | 0.820 | 2.900 | 4.800 | (*) | 5.61 | 11.23 | 18.43 |
| DZB-3CH-28V-50mA | (*) | 0.587 | 1.910 | 3.270 | (*) | 5.22 | 10.44 | 17.14 |
| DZB-3CH-36V-50mA | (**) | (**) | 1.070 | 1.930 | (**) | (**) | 9.44 | 15.49 |

| Barrier Type | Uo (V) | Io (mA) | Po (mW) | Lo/Ro (mH/Ω) IIC | Lo/Ro (mH/Ω) IIB | Lo/Ro (mH/Ω) IIA | Lo/Ro (mH/Ω) I |
|--------------------|-----------|------------|------------|------------------------|------------------------|------------------------|----------------------|
| DZB-2CHM-24/5-4/20 | 25.2 | 151.19 | 952.5 | 0.018 | 0.071 | 0.142 | 0.233 |
| DZB-2CHM-24/5 | 25.2 | 108.32 | 682.4 | 0.048 | 0.193 | 0.387 | 0.635 |
| DZB-2CHM-24/10 | 25.2 | 110.49 | 696.03 | 0.048 | 0.193 | 0.387 | 0.635 |

| Barrier Type | Co (μF) IIC | Co (μF) IIB | Co (μF) IIA | Co (μF) I | Lo (mH) IIC | Lo (mH) IIB | Lo (mH) IIA | Lo (mH) I |
|--------------------|-------------------|-------------------|-------------------|-----------------|-------------------|-------------------|-------------------|-----------------|
| DZB-2CHM-24/5-4/20 | 0.107 | 0.820 | 2.900 | 4.800 | 1.55 | 6.22 | 12.44 | 20.41 |
| DZB-2CHM-24/5 | 0.107 | 0.820 | 2.900 | 4.800 | 3.03 | 12.12 | 24.24 | 39.77 |
| DZB-2CHM-24/10 | 0.107 | 0.820 | 2.900 | 4.800 | 2.91 | 11.65 | 23.3 | 38.23 |

| Barrier Type | Uo (V) | Io (mA) | Po (mW) | Lo/Ro (mH/Ω) IIC | Lo/Ro (mH/Ω) IIB | Lo/Ro (mH/Ω) IIA | Lo/Ro (mH/Ω) I |
|-------------------|-----------|------------|------------|------------------------|------------------------|------------------------|----------------------|
| DZB-3CHM-24/5/5 | 25.2 | 153.45 | 966.74 | 0.017 | 0.069 | 0.137 | 0.225 |
| DZB-3CHM-24/10/10 | 25.2 | 88.39 | 556.82 | 0.056 | 0.224 | 0.448 | 0.735 |

| Barrier Type | Co (μF) IIC | Co (μF) IIB | Co (μF) IIA | Co (μF) I | Lo (mH) IIC | Lo (mH) IIB | Lo (mH) IIA | Lo (mH) I |
|-------------------|-------------------|-------------------|-------------------|-----------------|-------------------|-------------------|-------------------|-----------------|
| DZB-3CHM-24/5/5 | 0.107 | 0.820 | 2.900 | 4.800 | 1.5 | 6.03 | 12.07 | 19.81 |
| DZB-3CHM-24/10/10 | 0.107 | 0.820 | 2.900 | 4.800 | 4.55 | 18.2 | 36.41 | 59.73 |

Compliance drawings:

| Technical Documents | | | |
|--|------------|----------|------------|
| Title | Drawing | Revision | Date |
| Electronic schematic | LP700494 | H1 | 22/02/2021 |
| Printed circuit board artwork (Gerbers) | LP700494L | H1 | 14/08/2020 |
| Bill of materials | BOM700494 | 1 | 24/02/2021 |
| General assembly drawings * | D600806_1 | 5 | 01/11/2023 |
| General assembly drawings * | D600806_2 | 5 | 01/11/2023 |
| General assembly drawings * | D600806_3 | 5 | 01/11/2023 |
| Instruction manual | DZB Manual | 1 | 09/04/2021 |
| DZB Control drawing, 1 channel 6 V, 50 mA to 160 mA versions | D600807 | 1 | 12/02/2020 |
| DZB Control drawing, 1 channel 10 V, 50 mA to 160 mA versions | D600808 | 1 | 12/02/2020 |
| DZB Control drawing, 1 channel 12 V, 50 mA to 160 mA versions | D600809 | 1 | 12/02/2020 |
| DZB Control drawing, 1 channel 18 V, 50 mA to 160 mA versions | D600810 | 1 | 12/02/2020 |
| DZB Control drawing, 1 channel 24 V, 50 mA to 125 mA versions | D600811 | 1 | 12/02/2020 |
| DZB Control drawing, 1 channel 24 V, 160 mA only | D600812 | 1 | 12/02/2020 |
| DZB Control drawing, 1 channel 28 V, 50 mA & 80 mA versions | D600813 | 1 | 12/02/2020 |
| DZB Control drawing, 1 channel 28 V, 100mA & 125 mA versions | D600814 | 1 | 12/02/2020 |
| DZB Control drawing, 1 channel 36 V, 50 mA version only | D600815 | 1 | 12/02/2020 |
| DZB Control drawing, 1 channel 36 V, 80 mA & 100 mA versions | D600816 | 1 | 12/02/2020 |
| DZB Control drawing, 2 channel 6 V, 50 mA to 160 mA versions | D600817 | 1 | 12/02/2020 |
| DZB Control drawing, 2 channel 10 V, 50 mA to 160 mA versions | D600818 | 1 | 12/02/2020 |
| DZB Control drawing, 2 channel 12 V, 50 mA to 125 mA versions | D600819 | 1 | 12/02/2020 |
| DZB Control drawing, 2 channel, 18 V 50 mA, 80 mA & 100 mA versions | D600820 | 1 | 12/02/2020 |
| DZB Control drawing, 2 channel, 24 V 50 mA version only | D600821 | 1 | 12/02/2020 |
| DZB Control drawing, 2 channel, 28 V 50 mA version only | D600822 | 1 | 12/02/2020 |
| DZB Control drawing, 2 channel 36 V 50 mA version only | D600823 | 1 | 12/02/2020 |
| DZB Control drawing, mixed version 24V 50 mA and 5 V 40 mA | D600825 | 1 | 12/02/2020 |
| DZB Control drawing, mixed version 24 V 50 mA and 40 mA | D600826 | 1 | 12/02/2020 |
| DZB Control drawing, 2 channel mixed version 24 V 50 mA and 10 V 40 mA | D600827 | 1 | 12/02/2020 |
| DZB Control drawing, 3 channel mixed version 24V / 5V / 5V, 50 mA, 40 mA, 40 mA | D600828 | 1 | 12/02/2020 |
| DZB Control drawing, 3 channel mixed version 24 V / 10V / 10V, 50 mA, 40 mA, 40mA | D600829 | 1 | 12/02/2020 |
| DZB Control drawing, 3 channel 6 V version 50 mA, 80 mA, 100 mA, 125 mA, 160 mA | D600833 | 1 | 12/02/2020 |
| DZB Control drawing, 3 channel 10 V version 50 mA, 80 mA, 100 mA, 125 mA, 160 mA | D600834 | 1 | 12/02/2020 |
| DZB drawing, 3 channel 12 V version 50 mA, 80 mA, 100 mA, 125 mA | D600835 | 1 | 12/02/2020 |
| DZB Control drawing, 3 channel 18 V version 50 mA, 80 mA, 100 mA | D600836 | 1 | 12/02/2020 |
| DZB Control drawing, 3 channel 24 V 50 mA version only | D600837 | 1 | 12/02/2020 |
| DZB Control drawing, 3 channel 28 V 50 mA version only | D600838 | 1 | 12/02/2020 |
| DZB Control drawing, 3 channel 36 V 50 mA version only | D600839 | 1 | 12/02/2020 |
| 242 Series - Declaration of Suitability for Encapsulation or Conformal Coating rev 3 | N/A | 3 | 20/12/2017 |

Routine Tests

A routine test shall be carried out on each completed barrier to check correct operation of each barrier component and the fuses resistance.